

## **Radio Management Unit**

**RMU5000**

**RMU5000-1-XXXX**

**RMU5000-2-XXXX**

## **Installation and Operation**

Manual DV64301.03

Issue 04 February 2016

Article-No. 0541.958-071

**Blank Page**

## Preface

Dear Customer,

Thank you for purchasing a Becker Avionics product. We are pleased that you have chosen our product and we are confident that it will meet your expectations.

For development and manufacturing of our product, the guidelines for highest quality and reliability have been borne in mind, supplemented by selection of high quality material, responsible production and testing in accordance to the ISO 9001 and DIN EN 9100 standards.

Our competent customer support department will respond on any technical question you may have.

Please do not hesitate to contact us at any time.

## RMU5000 (Radio Management Unit)

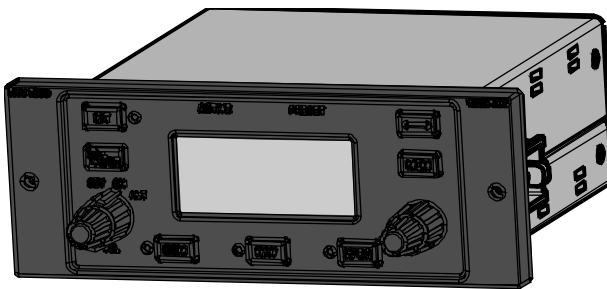

RMU5000 (160 mm version)

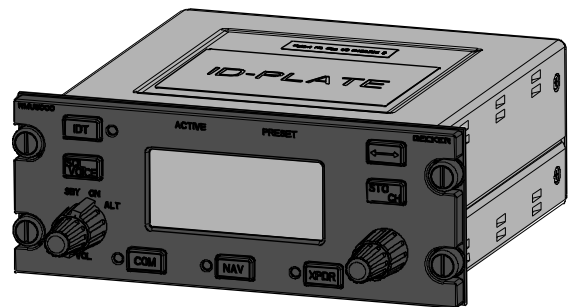

RMU5000 (DZUS version)

## List of Effective Pages and Changes

Only technical relevant modifications are described in this table.

<b>Document: DV64301.03 / issue 04 Article Number 0541.958-071</b>			
Cover Page	02/2016		
Introduction	02/2016		
Chapter 1 –4	02/2016		
Issue	Page No.:	Section / Chapter	Description
04	1...72	all	Changed: Editorial adjustments.
	--	1.3	Deleted: Table variants overview (unclear). Added: Cross reference "Order Code".
	--	1.5.6	Moved: Description "Tandem Operation" to chapter 2
	--	1.7.1	Changed: Description RMU5000-2-2110.
	--	2.6.2	Added: Description "Tandem Operation".
	--	2.6.3	Changed: Description Illumination voltage.
	--	2.7.2, 2.7.6	Updated: Descriptions about display indications.
	--	3.2.3	Changed: Description "Start-Up".
	--	3.2.4	Added: Description "All core modules OFF"
	--	3.3.1.9, 3.3.2.4, 3.3.3.2, 3.3.4.3	Updated: Description "Test Function" for: COM, NAV, XPDR, ADF.
	--	3.3.8	Changed: Description Tandem in general.
	--		
	--		
--			
--			

© 2016 by Becker Avionics GmbH / all rights reserved

## Table of Contents

<b>1. General Description .....</b>	<b>13</b>
1.1. Introduction.....	13
1.2. Purpose of Equipment.....	15
1.2.1. Associated Devices.....	15
1.3. Variants Overview .....	16
1.4. Safety-Conscious Utilization .....	17
1.4.1. COM Function .....	17
1.4.2. NAV Function .....	17
1.4.3. XPDR Function .....	18
1.4.4. ADF Function .....	18
1.5. General Electrical Description.....	19
1.5.1. Power on Built in Test (PBIT).....	19
1.5.2. Continuous Built in Test (CBIT) .....	19
1.5.3. Initiated Built in Test (IBIT) .....	19
1.5.4. Operation .....	19
1.5.5. Panel and Display Dimming/Illumination .....	20
1.6. Technical Data .....	21
1.6.1. Electrical Characteristics.....	21
1.6.2. Dimensions & Weight.....	21
1.6.3. Software.....	22
1.6.4. Approvals.....	22
1.6.5. Environmental Condition.....	22
1.7. Order Code.....	24
1.7.1. RMU5000.....	24
1.7.2. Accessories.....	24
<b>2. Installation.....</b>	<b>25</b>
2.1. Packaging, Transport, Storage .....	25
2.2. Device Assignment .....	26
2.2.1. Scope of Delivery.....	26
2.2.2. Additional Required Equipment .....	26
2.2.3. Type Plate.....	27
2.3. Mounting Requirements.....	28
2.4. Dimensions.....	28
2.4.1. RMU5000 - X - 1XXX (DZUS Version) .....	28
2.4.2. RMU5000 - X - 2XXX (160 mm Version).....	29
2.5. Connector Pin Assignments.....	30
2.5.1. Connector P1 (XPDR/ADF) .....	30
2.5.2. Connector P2 (NAV) .....	31
2.5.3. Connector P3 (COM).....	31
2.5.4. Connector J4 (Tandem).....	32
2.6. Aircraft Wiring.....	32
2.6.1. Electrical Bonding and Grounding .....	32
2.6.2. Tandem Operation (Master-Slave Operation) .....	33
2.6.3. Panel and Display Lighting .....	33
2.6.4. Wiring Diagrams RMU MASTER/SLAVE and Core Modules.....	34
2.6.4.1. RMU5000-1: COM – RT3209 /NAV/XPDR – ATC4401, ATC5401 .....	34
2.6.4.2. RMU5000-1: COM – RT6512 /NAV/XPDR – ATC3401 .....	35
2.6.4.3. RMU5000-2: COM – RT5202 /NAV – RN3320 /ADF – RA3502.....	36
2.7. Installation Setup.....	37
2.7.1. Service Mode Menu .....	37
2.7.2. Activation .....	37
2.7.3. Menu Screen Layout.....	37
2.7.4. Menu Contents.....	37
2.7.5. Select Menu Items .....	37

2.7.6.	Illumination Setup Screen .....	37
<b>3.</b>	<b>Operating Instructions .....</b>	<b>41</b>
3.1.	Device Description.....	41
3.1.1.	Device Assignment .....	41
3.1.2.	Packing, Transport, Storage .....	41
3.1.3.	Scope of Delivery .....	41
3.1.4.	Type Plate .....	41
3.2.	Controls and Indications .....	42
3.2.1.	User Interface RMU5000-1-XXXX .....	42
3.2.2.	User Interface RMU5000-2-XXXX .....	43
3.2.3.	Start-Up.....	44
3.2.3.1.	ROM Test Error.....	44
3.2.3.2.	RAM Test Error .....	44
3.2.3.3.	NVRAM Test Error .....	44
3.2.3.4.	IBIT (Initiated Build in Test).....	44
3.2.4.	All Core Modules OFF.....	45
3.3.	Operating.....	45
3.3.1.	COM Function .....	45
3.3.1.1.	Transmit Mode Indication .....	45
3.3.1.2.	Frequency Selector Function.....	45
3.3.1.3.	Exchange Function .....	45
3.3.1.4.	Squelch Function .....	45
3.3.1.5.	Channel Function.....	46
3.3.1.6.	Store Function.....	46
3.3.1.7.	Volume Adjustment.....	46
3.3.1.8.	ON/OFF Function.....	47
3.3.1.9.	Test Function .....	47
3.3.1.10.	Transmit/Receive Mode.....	47
3.3.1.11.	Jamming of Transmit Button.....	48
3.3.2.	NAV Function .....	48
3.3.2.1.	Frequency Selector Function.....	48
3.3.2.2.	Exchange Function .....	48
3.3.2.3.	Voice Function .....	48
3.3.2.4.	Test Function .....	49
3.3.2.5.	Channel Function.....	49
3.3.2.6.	Store Function.....	49
3.3.2.7.	ON/OFF Function.....	50
3.3.2.8.	Volume Adjustment.....	50
3.3.2.9.	VOR Mode .....	51
3.3.2.10.	LOC Mode.....	51
3.3.2.11.	GS Mode.....	51
3.3.3.	XPDR Function.....	51
3.3.3.1.	Exchange Function .....	51
3.3.3.2.	Test Function .....	52
3.3.3.3.	Code Selector Function .....	52
3.3.3.4.	Channel VFR Function .....	52
3.3.3.5.	Store VFR Function .....	52
3.3.3.6.	ON/OFF Function.....	53
3.3.3.7.	Warm-Up Function.....	53
3.3.3.8.	Flight Operation in the ON Mode .....	53
3.3.3.9.	Flight Operation in the ALT Mode.....	54
3.3.3.10.	Special Codes for Air Emergency.....	54
3.3.3.11.	RMU Switch-Off .....	55
3.3.4.	ADF Function .....	55
3.3.4.1.	Frequency Selector Function.....	55
3.3.4.2.	Exchange Function .....	55
3.3.4.3.	Test Function .....	56
3.3.4.4.	ADF Test Function .....	56
3.3.4.5.	Channel Function.....	56
3.3.4.6.	Store Function.....	56

3.3.4.7.	ON/OFF Function .....	57
3.3.4.8.	Volume Adjustment .....	57
3.3.4.9.	Operating Mode .....	57
3.3.4.10.	Receive Mode .....	58
3.3.4.11.	ADF Mode .....	58
3.3.4.12.	BFO Mode .....	58
3.3.4.13.	Emergency Mode .....	58
3.3.4.14.	COM / NAV Function .....	58
3.3.4.15.	REC / ADF / BFO Function .....	59
3.3.4.16.	Service Mode .....	59
3.3.5.	Menu for RMU5000 .....	59
3.3.5.1.	Software Version and Release .....	59
3.3.5.2.	Device Serial Number .....	59
3.3.5.3.	Device Type (Variants) .....	59
3.3.5.4.	Factory identification number (FIN) .....	60
3.3.5.5.	Leave the Service Mode .....	60
3.3.6.	Menu for RT3209 .....	60
3.3.6.1.	Frequency Channel .....	60
3.3.6.2.	Volume .....	60
3.3.6.3.	Squelch Level (SQL) .....	61
3.3.6.4.	Sidetone Level .....	61
3.3.6.5.	Auxiliary Input Level (AUX) .....	61
3.3.6.6.	Intercom Input Level .....	61
3.3.6.7.	Dynamic Mike Level (DMC) .....	62
3.3.6.8.	Internal Speaker Settings .....	62
3.3.6.9.	Self test .....	62
3.3.6.10.	Device Serial Number .....	62
3.3.6.11.	Recall Settings .....	63
3.3.7.	Menu for RT5202/RT6512 .....	63
3.3.7.1.	Frequency Channel .....	63
3.3.7.2.	Volume Level .....	63
3.3.7.3.	Squelch Level .....	64
3.3.7.4.	Sidetone Level .....	64
3.3.7.5.	Modulation Limiting Threshold .....	64
3.3.7.6.	OCXO Frequency Calibration .....	65
3.3.7.7.	RX AF AGC Limiting Threshold .....	65
3.3.7.8.	Temperature of Heat Sink .....	65
3.3.7.9.	Self test .....	66
3.3.7.10.	Errors and Error Flags Indication .....	66
3.3.7.11.	Last Inspection Date .....	68
3.3.7.12.	Operation Time .....	68
3.3.7.13.	Device Change Index .....	68
3.3.7.14.	Device Serial Number .....	68
3.3.7.15.	Recalling Settings .....	69
3.3.8.	Tandem Operation .....	69
<b>4.</b>	<b>Index .....</b>	<b>72</b>
	Figure 1: Type plate (example) .....	27
	Figure 2: RMU5000-X-1XXX (DZUS version) .....	28
	Figure 3: RMU5000-X-2XXX (160 mm version) .....	29
	Figure 4: RMU5000 connector layout rear side .....	30
	Figure 5: Wiring Diagram RMU5000-1-XXXX (COM – RT3209 /NAV/XPDR – ATC4401, ATC5401) .....	34
	Figure 6: Wiring Diagram RMU5000-1-XXXX (COM – RT6512 /NAV/XPDR – ATC3401) .....	35
	Figure 7: Wiring Diagram RMU5000-2-XXXX (COM – RT5202 /NAV – RN3320 /ADF - RA3502) .....	36
	Figure 8: Service Menu (screen layout) .....	37
	Figure 9: Backlight menu item .....	38
	Figure 10: Illumination Setup Screen .....	38
	Figure 11: Max. illumination point (x < 14/28 VDC), for example x = 5 V .....	39
	Figure 12: Max. illumination point (x = 14/28 VDC) .....	39
	Figure 13: Reduced max. illumination point (x = 14/28 VDC) .....	39
	Figure 14: Front panel RMU5000-1-XXXX .....	42
	Figure 15: Front panel RMU5000-2-XXXX .....	43

## List of Abbreviations

### List of Abbreviations

AC	Alternating Current
ACT	Activation
ADF	Automatic Direction Finder
A/D converter	Analog Digital Converter
AF	Audio Frequency Level
AIP	Aeronautical Information Publication
ALT	Altitude
ARINC	Aeronautical Radio Incorporation
ATC	Air Traffic Control
AUX	Auxiliary input level
BFO	Beat frequency oscillator
CBIT	Continuous Built-in Test
CM	Core Module
CPU	Control Processing Unit
DC	Direct Current
DDP	Declaration of Design and Performance
Dev.	Deviation
DMC	Dynamic mike level
DO	Document
EMC	Electromagnetic Compatibility
ENA	Enable
ESD	Electro Static Discharge
EUROCAE	European Organisation for Civil Aviation Electronics
E-PROM	Erasable Programmable Memory
EE-PROM	Electrically Erasable Programmable Memory
EXT	External Programmable Memory
FET	Field Effect Transistor
Fig.	Figure
FL	Flight Level
GND	Ground
GS	Glide Slope
HI	High
IBIT	Initiated Built-In Test
IC	Intercommunication
IDT	Transponder identactivation
ICAO	International Civil Aviation Organisation
I/O ports	Input/Output Ports
JTSO	Joint Technical Standard Order
LBA	Lufffahrt-Bundesamt
LCD	Liquid Crystal Display
LED	Light Emitting Diode



## List of Abbreviations

LO	Low
LP	Long Press
MEM	Memory key
MOS	Metal Oxid Semiconductor
MTBF	Mean Time Between Failure
N/A	Not Applicable
NAV	Navigation
NC	Not Connected
NOV-RAM	Non Volatile Random Access Memory
OUT	Output
OBS	Omni-bearing Selector
PBIT	Power On Built-In Test
PB	Test Report
PC	Personal Computer
POS	Position
PRG	Program Mode
PTT	Press to talk
PWR	Power
RAM	Random Access Memory
RF	Radio Frequency
RMU	Radio Management Unit
ROM	Read Only Memory
RTCA	RTCA, Inc.
SBY	Stand by
SIG	Signal indication
SID	Side tone level
S/N	Serial-No.
SQL	Squelch
SPE	Specification
SP	Circuit Diagram
SPK	Speaker
VDC	Continuous Voltage
Vpp	Voltage peak to peak
VOL	Volume
VOR	VHF Omni-directional Radio Range
VHF	Very High Frequency
XPDR	Transponder

## Units

### Units

A	Ampere
mA	Milliampere

## Units

°C	Degree Celsius
cm	Centimetre
dBm	Power Ratio in Decibel
dB	Decibel
ft	Feet, Foot
g	Gram
kg	Kilogram
kHz	Kilohertz
MHz	Megahertz
Mbps	Mega bits per second
mm	Millimetre
Ohm ( $\Omega$ )	Resistance
s	Second
V	Volt
mV	Millivolt
W	Watt
mW	Milliwatt
"	Inch
°	Angular Degree

## General Safety Definitions

 **DANGER** Indicates a hazardous situation which, if not avoided, will result in death or serious injury.

 **WARNING** Indicates a hazardous situation which, if not avoided, could result in death or serious injury.

 **CAUTION** Indicates a hazardous situation which, if not avoided, could result in minor or moderate injury.

 **NOTICE** Is used to address practices not related to physical injury.

 **SAFETY INSTRUCTIONS** Safety instructions (or equivalent) signs indicate specific safety-related instructions or procedures.

## Disposal

 **CAUTION** The packaging material is inflammable, if it is disposed of improperly by burning, lethal fumes may develop.

This product contains materials that fall under the special disposal regulation, which corresponds to the EC directive for dangerous disposal material. We recommend disposing of the respective materials in accordance with the respectively valid environmental laws. The following table states the materials suitable for recycling and the materials which have to be disposed of separately.

Material	Suitable for recycling	Disposal
Metal	yes	no
Plastics	yes	no
Circuit boards	no	yes

Dispose of the circuit boards:

- Disposal via a technical waste dump which is allowed to take on e.g. electrolytic aluminium capacitors. Do under no circumstances dump the circuit boards with normal waste dump.

## Warranty Conditions

User Conversions and Changes are Not Permitted

Any change made by the user excludes any liability on our part (excluding updates for the navigation data base).

- The device must not be opened.
- Do not make any modifications to the device, except for those described in the manual.
- Make connections to the inputs, outputs and interfaces only in the manner described in the manual.
- Fix the devices according to the **mounting instructions**. We cannot provide any guarantee for other mounting methods.

## Conditions of Utilization

### General introductory notes

With this device you bought a product which was manufactured and tested before delivery with the utmost care.

Please take your time to read the following notes which you ought to follow closely during installation and operation.

Unless, all claims under the warranty will become void and a reduced service life or even damages must be expected.

### **⚠ CAUTION**

The user is responsible for protective covers and/or additional safety measures in order to prevent damages to persons and electric accidents.

### Additional Conditions of Utilization

Please refer to "Safety-Conscious Utilization" page 17.

### Non Warranty Clause

We checked the contents of this publication for compliance with the associated hard and software. We can, however, not exclude discrepancies and do therefore not accept any liability for the exact compliance. The information in this publication is regularly checked, necessary corrections will be part of the subsequent publications.

## 1. General Description

### In this chapter you can read about:

1.1. Introduction.....	13
1.2. Purpose of Equipment.....	15
1.2.1. Associated Devices.....	15
1.3. Variants Overview .....	16
1.4. Safety-Conscious Utilization .....	17
1.4.1. COM Function.....	17
1.4.2. NAV Function.....	17
1.4.3. XPDR Function .....	18
1.4.4. ADF Function .....	18
1.5. General Electrical Description.....	19
1.5.1. Power on Built in Test (PBIT).....	19
1.5.2. Continuous Built in Test (CBIT).....	19
1.5.3. Initiated Built in Test (IBIT) .....	19
1.5.4. Operation .....	19
1.5.5. Panel and Display Dimming/Illumination .....	20
1.6. Technical Data .....	21
1.6.1. Electrical Characteristics.....	21
1.6.2. Dimensions & Weight.....	21
1.6.3. Software.....	22
1.6.4. Approvals.....	22
1.6.5. Environmental Condition.....	22
1.7. Order Code.....	24
1.7.1. RMU5000.....	24
1.7.2. Accessories.....	24

The RMU5000 (Radio Management Unit) is part of a radio management system and intended for installation in an aircraft. It serves for the control of up to three remote-controlled core modules. The RMU5000-1-XXXX can be operated with the core modules COM, NAV and XPDR.

The RMU5000-2-XXXX can be operated with the core modules COM, NAV and ADF.

### 1.1. Introduction

This manual describes the operation and installation of the RMU5000 (Radio Management Unit) equipment. The ID label on your device shows the part number for identification purposes (see "Type Plate", page 27).

Before starting operation of the unit(s) please read this manual carefully, with particular attention to the description referring to your device(s). This manual also contains several optional elements of the system that may not be contained in your delivery package and in that case are not applicable.

For further descriptions we are using the term RMU5000 instead of writing the complete model number.

The manuals DV 64301.04 **M&R** ("Maintenance and Repair") and DV 64301.03 **I&O** ("Installation and Operation") contain the following sections:

Section		DV 64301.04 M&R	DV 64301.03 I&O	-
1	General	X	X	
2	Installation	X	X	
3	Operation	X	X	
4	Theory of Operation	X	N/A	
5	Maintenance and Repair	X	N/A	
6	Illustrated Parts List	X	N/A	
7	Modification and Changes	X	N/A	
8	Circuit Diagrams	X	N/A	
9	Certifications	X	N/A	
10	Attachments	X	N/A	

## 1.2. Purpose of Equipment

The RMU5000-X-1XXX is designed for installation in the instrument panel or in the operating console of aircraft. The dimensions correspond to the ARINC 601 standard for control units.

Installation is by means of four DZUS fasteners (DZUS version) respectively with four screws (160 mm version). For details see "Dimensions", page 28.

All controls and indicators are located on the front panel. For details see "User Interface", page 42 and "User Interface", page 43.

The three core module connectors (COM, NAV, ADF or XPDR) and one unit connector for two Radio Management Units (tandem) are fitted on the back.

The RMU5000 (Radio Management Unit) consists of the following electrical assemblies respectively circuit boards:

- Mother Board,
- Processor Board,
- Switch Board,
- Interface Board,
- Panel Board,
- LC Display Board.

It is a rigid design for the operation in fixed wing and rotary wing aircraft.

### 1.2.1. Associated Devices

Following Becker devices can operate with RMU5000-1-XXXX or RMU5000-2-XXXX.

Module	Function
RT3209-(11)	VHF COM Transceiver
RT5202	VHF COM Transceiver
RT6512	VHF COM Transceiver
RN3320-(XX)	VOR/ILS NAV Receiver
RA3502	ADF Receiver
ATC3401-(1)-R	XPDR Transponder
ATC4401-2-XXX	XPDR Transponder
ATC5401-1R-(01)	XPDR Transponder

### 1.3. Variants Overview

Within the part number, the meaning of "-X-XXX " is:

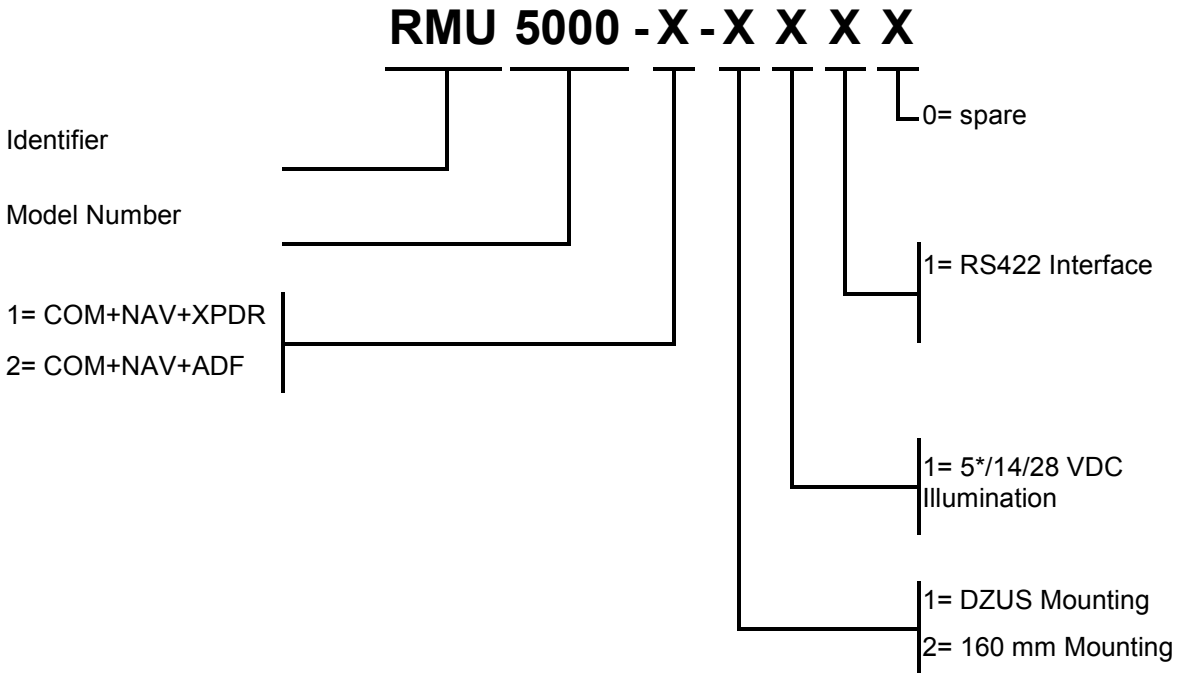

\* 5 V from Mod.1.

available variants please see "Order Code", page 24.



## 1.4. Safety-Conscious Utilization

### NOTICE

For safe operation of Radio Management Unit (RMU) the following notes have to be followed :

- Do not connect the unit to an AC voltage or voltage source of more than 30.3 VDC.
- Do not connect the unit to a power source with the polarities incorrect.
- Protect the unit from the aircraft system by its own 1 A circuit breaker.

### NOTICE

Switch off the system when starting engines!

### 1.4.1. COM Function

#### SAFETY INSTRUCTIONS

A voice communication test shall be performed before starting the engine.

It should be noted that, if the communication test is carried out close to a ground station, the results may be positive even if the antenna cable is broken or short-circuited. In such a case, at a distance of 5 to 10 km and above, communication might not be possible.

- Speak always loud, clear and not too fast for optimal voice communication.
- Keep the microphone always close to the lips otherwise a special suppressing circuit in the VHF COM will not be capable to suppress normal cabin noise.
- Use only microphones or headsets which are suitable for use in an aircraft.
- Transmit buttons can stick and cause continuous transmission. Observe the TX indication in the display.

### 1.4.2. NAV Function

#### SAFETY INSTRUCTIONS

- Reception is only possible when there is a quasi-optical sight to the VOR station.
- When flying with the autopilot locked on to VOR, the OBS must not be rotated because any change in the off-course needle is followed by the autopilot.

#### SAFETY INSTRUCTIONS

- When the warning flag in the indicator appears, the course deviation needle is in the mid-position, it must then not be used in the continuing flight!
- If the off-course needle instrument fails, no warning flag appears. Check the off-course needle by activating the TEST function. The off-course needle must deflect halfway. Important to check before approach to landing.
- During approaches on the back beam, a needle deflection no longer corresponds to a command indication. In this special case, course corrections must be made opposite to the needle deflection!

#### SAFETY INSTRUCTIONS

- When overflying VOR stations a cone of silence of 45° occurs in which the warning flag appears and the off-course needle stays in the mid position.
- When flying over mountains the VOR needle may deviate about the mid position (reflections) when approaching or leaving VOR stations. The doubler VOR stations produce substantially more stable indications under these conditions.

**SAFETY INSTRUCTIONS**

EMC note: If the antennas of core modules COM and NAV are not sufficiently decoupled, it is possible that the warning flag may appear during transmission or the off-course needle may deflect. Inadequate decoupling is possible with airframes made of wood or synthetic materials or where the antennas are mounted close together.

**1.4.3. XPDR Function**

**SAFETY INSTRUCTIONS**

Do not set a code with 75XX / 76XX / 77XX. These special codes are reserved for emergencies. See "Special Codes for Air Emergency", page 54.

In the ON and ALT modes, the identification pulse is transmitted in addition to the reply code for approximately 25 seconds only in response to Mode A requests.

**1.4.4. ADF Function**

ADF equipment is sensitive to radio interference. This includes:

- Atmospheric interference caused by weather conditions (thunder storms, thunder storm conditions).
- Static charging of the aircraft airframe when flying in wet conditions with ice particles. Both can lead to uncontrolled deflections of the indicator. In the case of static charging the reception from an NDB station can be completely lost for several minutes;
- Interference in the aircraft supply system caused by generators or ignition systems can considerably reduce the range to NDB stations. The following checks can be made during flight;
  - If there is interference when receiving an NDB station:
    - Switch off the generator for a short period and observe the effect;
    - In the case of piston-engine aircraft switch the ignition from magneto 1 to magneto 2 and to 0 in succession. Observe the effect. If the cause of the interference is identified, initiate ground maintenance procedures!
- Effect during twilight and night: Unusable bearings can occur particularly during twilight if the change in the ionisation layer effects the phases of ground and space waves. It is also possible for these effects to occur at night.
- Coastal errors: When flying over the sea, bearing errors can occur due to refraction of electromagnetic waves at the coast. Further possible causes of incorrect bearings are: steep banking flight; flying with the landing gear down.
- When overflying an NDB station the pointer of the indicator should ideally move through 90° (station on the right) or 270° (station on the left) before stabilizing in the 180° direction after the overflight.
- Due to a cone of uncertainty of 45°, which is due to physical conditions, it must be borne in mind that an unstable indication during the flight will be produced by the cone of uncertainty resulting in multiple pointer deflections. After the aircraft has left the cone, the indication stabilizes at 180°. This can differ from NDB to NDB.
- Correct approaches to radio transmitters are therefore only possible if they are expressly performed as navigational aids in the AIP.

## 1.5. General Electrical Description

After power on, an initialization phase starts between the radio management unit and core modules (COM, NAV, ADF or XPDR). During this period, data transmission is done from the remote core module to the radio management unit. The display pixels and LEDs are activated, then identification and system data shown for 5 seconds. This is necessary because the data backup takes place in the remote core modules. On completion of this phase, the setting of the mode switch before power off is automatically reactivated and displayed on the radio management unit.

The RMU5000 provides the following self test capabilities:

### 1.5.1. Power on Built in Test (PBIT)

The tested elements are:

- Program object code - ROM memory
- RAM memory
- NVRAM buffer
- NVRAM contents - persistent data

GO	FAIL
The system starts to work.	The system shows an error message and needs maintenance.

### 1.5.2. Continuous Built in Test (CBIT)

The continuous self test is always running in the background. The tested elements are:

- Interrupt system
- Communication lines

GO	FAIL
The system continues working.	The system shows an error message.

### 1.5.3. Initiated Built in Test (IBIT)

The initiated self test is being accessible by entering the Menu mode and pressing the Test button with a long press. Generally the IBIT and PBIT are identical for the content of the test.

GO	FAIL
The system continues working.	The system shows an error message and needs maintenance.

### 1.5.4. Operation

- The respective function is selected by pressing the buttons COM, NAV, XPDR or COM, NAV, ADF. The frequencies are indicated by means of a LCD display.
- In function COM /NAV and ADF the desired active operating frequencies can be set on the LCD display by means of the MHz and kHz frequency selector switches respectively the code for the XPDR function.
- The MHz rotary switch changes in steps of 1 MHz (COM/NAV). Depending on the associated core module, the kHz rotary switch (COM/NAV) changes in 50 kHz, 25 kHz or 8.33 kHz steps. In frequency preselection mode, a quick frequency change between the set active frequency and the preset frequency is achieved by pressing the (exchange key).
- A storage device enables 9 different frequencies per core module (COM/NAV/ADF) and one VFR code (XPDR) to be stored, in a non-volatile memory.
- Data transmission between the radio management unit and core modules takes place via a bidirectional, serial RS422 interface.

#### 1.5.5. Panel and Display Dimming/Illumination

- The dimming entry is either 5 VDC or 14 or 28 VDC.
- The system has to generate 2 different pulse width signals to support
  - Dimming of the panel.
  - Dimming of the display and indications.
- The panel can be dimmed from off to full illumination, the display has minimum illumination to ensure that the indications are always visible.
- The characteristic of the dimming and illumination is adapted by a software service setup which can be called up during power on.

## 1.6. Technical Data

### 1.6.1. Electrical Characteristics

RMU5000	Specifications
Power supply	9...30.3 V
Current consumption (without panel illumination)	500 mA at 27.5 V
Operating temperature	-20...+ 55 °C
Short time temperature	+70 °C
Storage temperature	-55...+ 85 °C
Altitude max.	50 000 ft
Memory capacity COM/NAV/ADF	9 channels
Memory capacity XPDR	1 code
MTBF	5000 hours
Interface	RS422
Speed	COM 9.6 kbps NAV 9.6 kbps ADF 9.6 kbps XPDR 4.8 kbps RMU 19.2 kbps
Data transfer	TTL level (positive logic) 0: ground (less than 22 Ω or 0...3.5 VDC) 1: +5 VDC (sinking up to 25 mA) Z: more than 100 k to ground)
Self Test	Built In Test (PBIT, CBIT, IBIT)
Display technology	LCD (positive) with backlight monochrome
Effective Display resolution	86x31 pixels
View angle	45° with 12 o'clock preferred viewing angle
Backlight color	amber
LED color	amber

### 1.6.2. Dimensions & Weight

RMU5000	Specifications
Dimensions HxWxD (DZUS version)	56.8 x 145.8 x 172.2 mm (2.24 x 5.74 x 6.77 inch)
Dimensions HxWxD (160 mm version)	59.8 x 160 x 172.2 mm (2.35 x 6.3 x 6.77 inch)
Weight	DZUS version: < 0.75 kg
	160 mm version: < 0.90 kg (including mounting frame)
Panel color	RAL 9005 (black)

### 1.6.3. Software

All data such as the set frequencies, stored frequencies, selected mode etc. are stored in the core modules. If the control elements are altered, a data transmission immediately takes place to the remote core module. The frequency display is controlled by a microcontroller. The software is classified as level C in accordance with the EUROCAE/RTCA document ED12B/DO-178B.

### 1.6.4. Approvals

RMU5000	
LBA-No.:	LBA.O.10.530/01 JTSO Specifications
JTSO	JTSO-2C37d (COM-TX), JTSO-2C38d (COM-RX), JTSO-2C40c (VOR), JTSO-C36e (LOC), JTSO-C74c (ATC), JTSO-2C41 (ADF)
TSO	TSO-C37d, TSO-C38d, TSO-C36e, TSO-C40c, TSO-C41d, TSO-C74c
Software	EUROCAE/RTCA ED12B/DO - 178B Level C
Vibration resistance in accordance with EUROCAE / RTCA ED-14D /DO-160D	Category S / vibration curve M Category U / vibration curve G
Humidity resistance in accordance with EUROCAE / RTCA ED-14D /DO-160D	Cat. A
Environmental categories according to ED-14D /DO-160D D1Z BAB [(SM)(UG)] XXXXXXZBABA[WW]B [XXXX] XXA	Env. Cat. EUROCAE / RTCA

### 1.6.5. Environmental Condition

The following resistances to environmental influences were verified in accordance with EUROCAE / RTCA DO-160D change 2.

Condition	Section	Cat.	Description
Temperature	4.0	D1	
Low Ground Survival Temperature (storage temperature)			-55 °C
Short-Time Operating Low Temperature			-
Low Operating Temperature	4.5.1		-20 °C
High Ground Survival Temperature (storage temperature)	4.5.2		+85 °C
High Short-Time Operating Temp.		+70 °C	
High Operating Temperature	4.5.3		+55 °C
In-flight Loss of Cooling	4.5.4	Z	No auxiliary cooling required
Max Operating Altitude	4.6.1	D1	50 000 ft
Decompression			
Overpressure			
Temperature Variation	5.0	B	5 °C per minute
Humidity	6.0	A	48 h @50 °C, 95 % relative humidity
Shock and Crash Safety	7.0	B	
Operational Shocks	7.2.1		11 ms 6 G

Condition	Section	Cat.	Description
Crash Safety (Impulse)	7.3.1		11 ms 20 G
Crash Safety (Sustained)	7.3.2		20 G for 3 s in each direction
Vibration	8.0	UG SM	Equipment tested to Category S, aircraft zone 2 for fixed-wing reciprocating and turboprop multi engine over 5700 kg, multi engine less than 5700 kg and single engine less than 5700 kg aircraft using vibration curve M. Equipment tested to Category U, aircraft zone 2 for helicopters fixed-wing reciprocating and turbojet engine using vibration curve G.
Explosion Proofness	9.0	X	
Water Proofness	10.0	X	
Fluids Susceptibility	11.0	X	
Sand and Dust	12.0	X	
Fungus Resistance	13.0	X	
Salt Spray	14.0	X	
Magnetic Effect	15.0	Z	Deflection of 1° of compass at a distance of 30 cm.
Power Input Variation	16.0	B	9...30.3 V
Voltage Spike	17.0	A	
Audio Freq. Conducted Susceptibility	18.0	B	
Induced Signal Susceptibility	19.0	A	
Radio Frequency Susceptibility	20.0	WW	
Emission of Radio Frequency Energy	21.0	B	
Lightning Induced Transients Susceptibility	22.0	XXXX	
Lightning Direct Effects	23.0	X	
Icing	24.0	X	
Electrostatic Discharge (ESD)	25.0	A	15 000 V

## 1.7. Order Code

### 1.7.1. RMU5000

Qty	RMU5000 (Radio Management Unit)	
1	<b>RMU5000-1-1110</b> COM/NAV/XPDR / DZUS / Illumination 5/14/28 V / RS422	Art.-No.: 0534.552-908
1	<b>RMU5000-1-2110</b> COM/NAV/XPDR / 160 mm / Illumination / 5/14/28 V / RS422	Art.-No.: 0534.560-908
1	<b>RMU5000-2-1110</b> COM/NAV/ADF / DZUS / Illumination 5/14/28 V / RS422	Art.-No.: 0534.579-908
1	<b>RMU5000-2-2110</b> COM/NAV/ADF / 160 mm / Illumination 5/14/28 V / RS422	Art.-No.: 0534.587-908

### 1.7.2. Accessories

Qty	Connector kit for RMU5000	
1	CK-5015-S, 15-pol soldering version	Article-No. 0552.925-954
1	CK-5015-C, 15-pol crimp version	Article-No. 0552.933-954
1	CK-5009-S, 9-pol soldering version	Article-No. 0556.671-954
1	CK-5009-C, 9-pol crimp version	Article-No. 0556.688-954

Qty	Manuals	
1	DV64301.03 Installation & Operation (English)	Article-No. 0541.958-071
1	DV64301.04 Maintenance & Repair (English)	Article-No. 0541.966-071



## 2. Installation

This manual must be available close to the device during the performance of all tasks.

Careful planning should be applied to achieve the desired performance and reliability from the product. Any deviations from the installation instructions prescribed in this document are under own responsibility.

The installation of the RMU5000 depends on the type of aircraft and equipment and therefore only general information can be given in this section.

### In this chapter you can read about:

2.1. Packaging, Transport, Storage .....	25
2.2. Device Assignment .....	26
2.2.1. Scope of Delivery .....	26
2.2.2. Additional Required Equipment .....	26
2.2.3. Type Plate .....	27
2.3. Mounting Requirements .....	28
2.4. Dimensions .....	28
2.4.1. RMU5000 - X - 1XXX (DZUS Version) .....	28
2.4.2. RMU5000 - X - 2XXX (160 mm Version) .....	29
2.5. Connector Pin Assignments .....	30
2.5.1. Connector P1 (XPDR/ADF) .....	30
2.5.2. Connector P2 (NAV) .....	31
2.5.3. Connector P3 (COM) .....	31
2.5.4. Connector J4 (Tandem) .....	32
2.6. Aircraft Wiring .....	32
2.6.1. Electrical Bonding and Grounding .....	32
2.6.2. Tandem Operation (Master-Slave Operation) .....	33
2.6.3. Panel and Display Lighting .....	33
2.6.4. Wiring Diagrams RMU MASTER/SLAVE and Core Modules .....	34
2.6.4.1. RMU5000-1: COM – RT3209 /NAV/XPDR – ATC4401, ATC5401 .....	34
2.6.4.2. RMU5000-1: COM – RT6512 /NAV/XPDR – ATC3401 .....	35
2.6.4.3. RMU5000-2: COM – RT5202 /NAV – RN3320 /ADF – RA3502 .....	36
2.7. Installation Setup .....	37
2.7.1. Service Mode Menu .....	37
2.7.2. Activation .....	37
2.7.3. Menu Screen Layout .....	37
2.7.4. Menu Contents .....	37
2.7.5. Select Menu Items .....	37
2.7.6. Illumination Setup Screen .....	37

### 2.1. Packaging, Transport, Storage

Visually inspect the package contents for signs of transport damage.

#### Packaging Material and Transport



The packaging material is inflammable, if it is disposed of improperly by burning, lethal fumes may develop.

The packaging material can be kept and reused in the case of a return shipment. Improper or faulty packaging may lead to transport damages.

Make sure to transport the device always in a safe manner and with the aid of suitable lifting equipment if necessary. Do never use the electric connections for lifting. Before the transport, a clean, level surface should be prepared to place the device on. The electric connections may not be damaged when placing the device.

**First Device Checkup**

- Check the device for signs of transport damages.
- Please verify if the indications on the type plate correspond to your purchase order.
- Check if the equipment is complete ("Scope of Delivery", page 26).



Do not use products with damages!

**Storage**

If you do not wish to mount and install the device immediately, make sure to store it in a dry and clean environment. Make sure that the device is not stored near strong heat sources and that no metal chippings can get into the device.

**2.2. Device Assignment**

This manual is valid for the following devices:

- RMU5000-1-XXXX + supplement
- RMU5000-2-XXXX + supplement

**2.2.1. Scope of Delivery**

- Manuals
  - Installation & Operation manual (English)
- Radio Management Unit
  - RMU5000 (corresponding to your ordered version)
- Documents of Certifications if available

**2.2.2. Additional Required Equipment**

- Connector kit

Details see "Accessories", page 24.

### 2.2.3. Type Plate

The device type is defined by the type plate (on the housing):

Example:

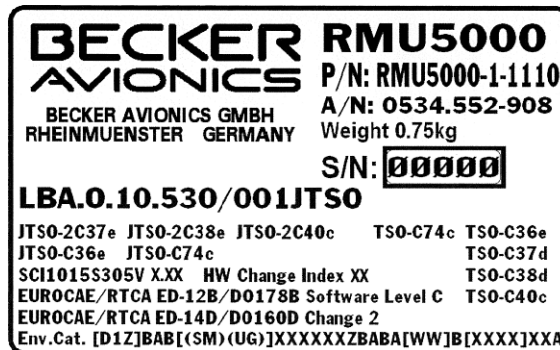

Figure 1: Type plate (example)

#### Explanation:

<b>P/N:</b>	<b>Type designation:</b> <b>RMU5000:</b> Abbreviation for Radio Management Unit Series 5000  <b>Options:</b> -1-XXXX: COM/NAV/XPDR -2-XXXX: COM/NAV/ADF -X-1XXX: DZUS version -X-2XXX: 160 mm version -X-X1XX: Illumination 5/14/28 V -X-XX1X: RS422 -X-XXX0: Spare
<b>SN:</b>	Unique number of the particular device
<b>AN:</b>	Article number (XXXX.XXX-XXX)
<b>Software:</b>	Corresponding to the displayed version
<b>Compliance and Certifications</b>	Corresponding to the displayed text and logos

### 2.3. Mounting Requirements

**SAFETY INSTRUCTIONS**

The device must not be opened.

When installing the device, make sure the heat dissipators of the device receive sufficient air. Keep an efficient distance of the devices with integrated ventilator fans in order to ensure free circulation of the cooling air.

Make sure that the mounting plate is not exposed to external temperature influences.

### 2.4. Dimensions

#### 2.4.1. RMU5000 - X - 1XXX (DZUS Version)

Dimensions mm (inch)

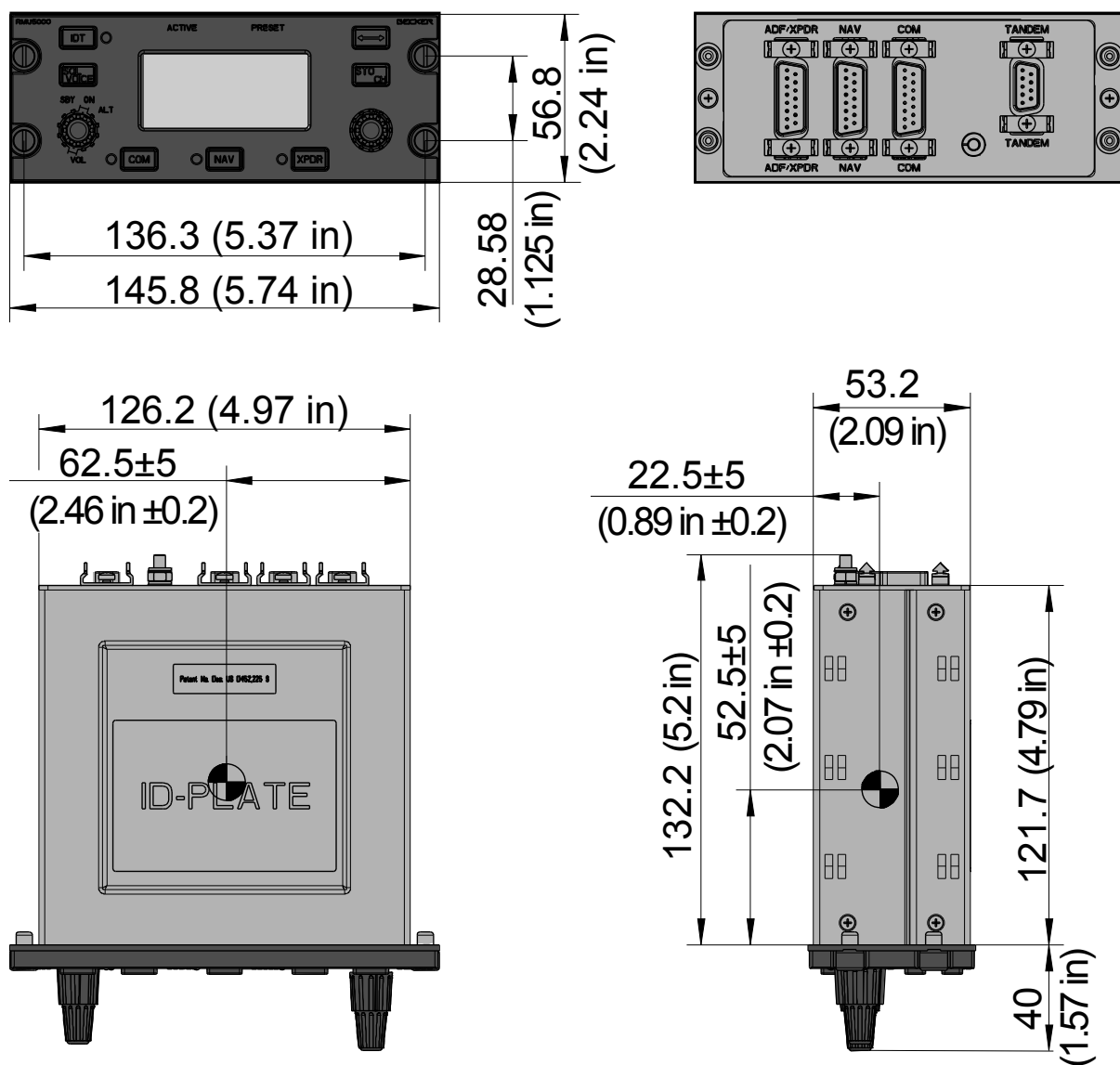
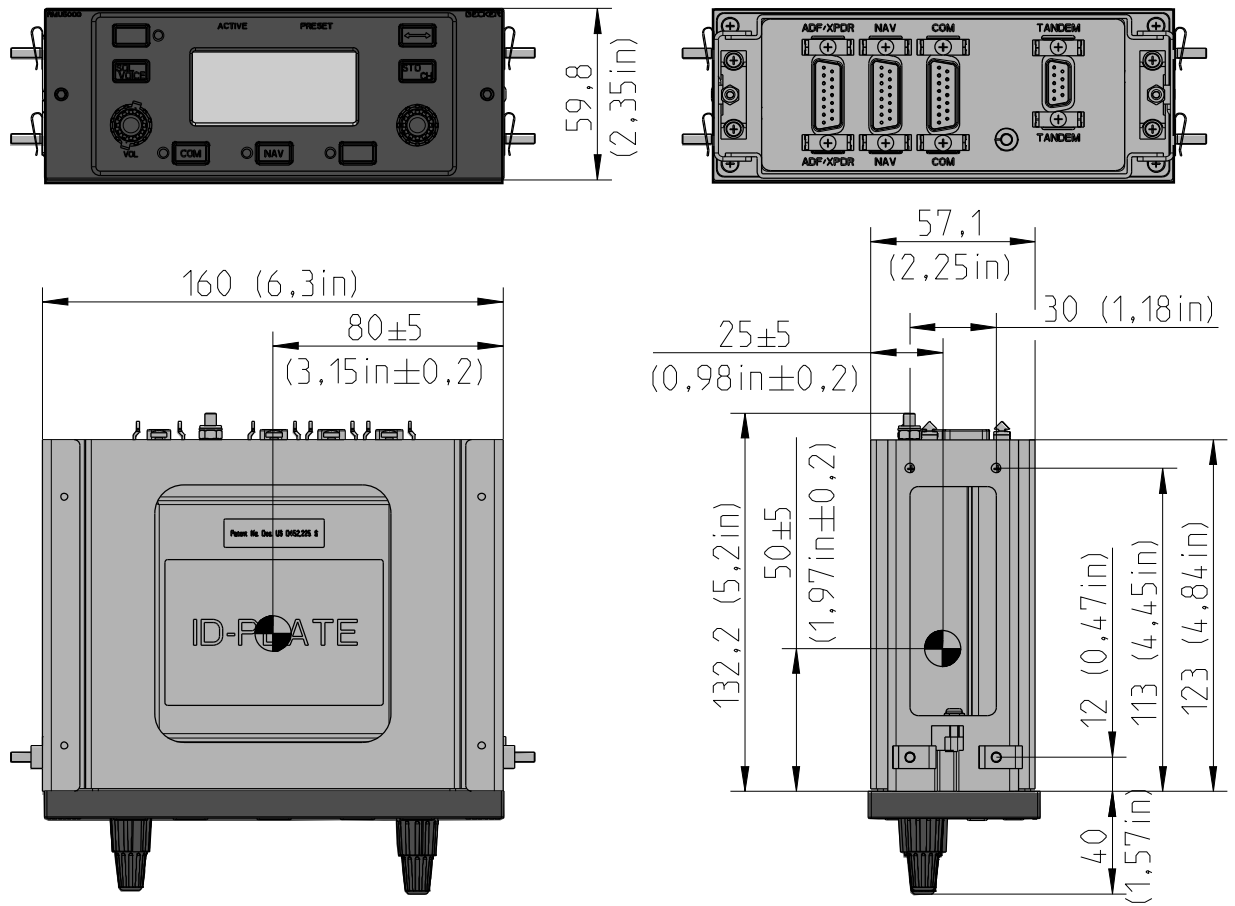



Figure 2: RMU5000-X-1XXX (DZUS version)

2.4.2. **RMU5000 - X - 2XXX (160 mm Version)**

Dimensions mm (inch)



 CENTER OF GRAVITY

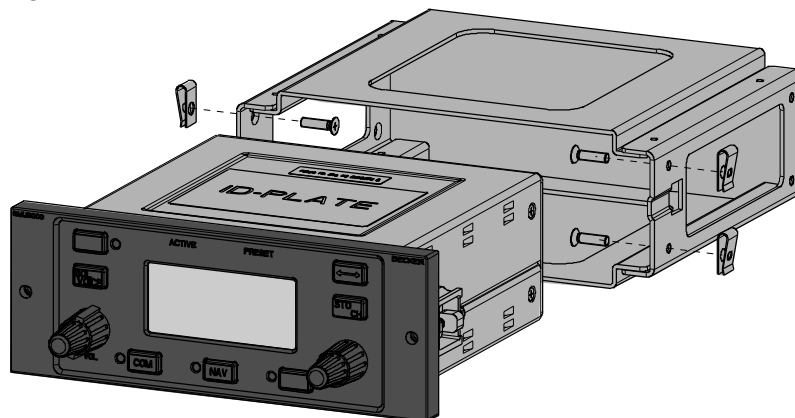

Figure 3: RMU5000-X-2XXX (160 mm version)

## 2.5. Connector Pin Assignments

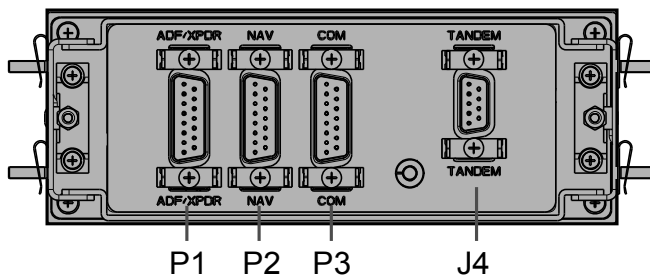

Figure 4: RMU5000 connector layout rear side

### 2.5.1. Connector P1 (XPDR/ADF)

Pin	Pin name	Function
1	TX-A1	RS422 Interface
2	TX-B1	RS422 Interface
3	not used	not used
4	RX-A1	RS422 Interface
5	RX-B1	RS422 Interface
6	Ill.A	Illumination A
7	not used	not used
8	Ill.B	Illumination B
9	GND	Ground
10	/Connect1	Plug control line 1
11	+ Supp. Volt.	+Supply Voltage
12	+ Supp. Volt.	+Supply Voltage
13	/ON1	On/Off control line1
14	not used	not used
15	Ext. IDT not used	control line (ATC) not used (ADF)

**Remarks:**

14 V wiring: Pin6 (Ill.A) to 5...14 V and Pin8 (Ill.B) to GND.

28 V wiring: Pin6 (Ill.A) to GND and Pin8 (Ill.B) to 10...28 V.

### 2.5.2. Connector P2 (NAV)

Pin	Pin name	Function
1	TX-A2	RS422 Interface
2	TX-B2	RS422 Interface
3	not used	not used
4	RX-A2	RS422 Interface
5	RX-B2	RS422 Interface
6	III.A	Illumination A
7	not used	not used
8	III.B	Illumination B
9	GND	Ground
10	/Connect2	Plug control line 2
11	+ Supp. Volt.	+Supply Voltage
12	+ Supp. Volt.	+Supply Voltage
13	/ON2	On/Off control line
14	not used	not used
15	not used	not used

### 2.5.3. Connector P3 (COM)

Pin	Pin name	Function
1	TX-A3	RS422 Interface
2	TX-B3	RS422 Interface
3	not used	not used
4	RX-A3	RS422 Interface
5	RX-B3	RS422 Interface
6	III.A	Illumination A
7	not used	not used
8	III.B	Illumination B
9	GND	Ground
10	/Connect3	Plug control line 3
11	+Supp. Volt.	+Supply Voltage
12	+Supp. Volt.	+Supply Voltage
13	/ON3	On/Off control line
14	not used	not used
15	/PTT	PTT control line

### 2.5.4. Connector J4 (Tandem)

Pin	Pin name	Function
1	UB-IN	+Supply voltage input
2	UB-OUT	+Supply voltage output
3	/ON	On/Off control line
4	RX-A	RS422 interface
5	RX-B	RS422 interface
6	GND	Ground
7	/CONNECT	Plug control line
8	TX-A	RS422 interface
9	TX-B	RS422 interface

## 2.6. Aircraft Wiring

### SAFETY INSTRUCTIONS

The following points are to be observed for the wiring:

- Only cable fit for aviation (self-extinguishing) may be used. AWG 20 for power supply and AWG 24 for other cables.
- The interface lines TX-A/TX-B and RX-A/RX-B are each to be laid as 2-core twisted and screened (AWG 24) cables.
- Rubber sleeves are to be fitted over the soldering points on the unit connector.
- A fuse or circuit breaker should be fitted in the power supply of the core modules (see aircraft wiring diagrams).
- No RF cable should be included in the cable harnesses. A bundle of connecting cables together with cables which carry AF power or pulses is also to be avoided.
- Check the wiring carefully before switching on the Control units and core module, particularly that (UB+) and (GND) have not been mixed up.

### 2.6.1. Electrical Bonding and Grounding

### SAFETY INSTRUCTIONS

- Make sure that the control panel is correctly connected to aircraft ground (structure).
- Make sure that the electrical continuity between the control panel and the structure is also achieved without removing the protective finish at the attachment points.
- Note that the electrical bonding area shall be adequately sealed or coated in order to avoid corrosion.
- Note that the resistance between the component which ensure equipment bonding and any point of this item of equipment do not exceed 20 mΩ.



**2.6.2. Tandem Operation (Master-Slave Operation)**

If two Radio Management Units are used, the Radio Management Unit to which the core modules are attached is determined as the MASTER unit.

The software recognizes the attached core module and makes the MASTER/SLAVE assignment.

Generally the SLAVE unit displays the same information as the MASTER unit with the following restrictions:

- The SLAVE RMU5000 can have a separate illumination curve, setable via "Illumination Setup Screen", see page 37. The illumination voltage is the same as applied on the MASTER RMU5000.
- The SLAVE RMU5000 is connected to MASTER via connector "Tandem J4" only. Do not use P1, P2, P3 at all on the SLAVE RMU5000.

**2.6.3. Panel and Display Lighting**

The radio management unit is fitted out with panel and display lighting. It can also be connected via a dimmer system.

Connection panel and display lighting	Illumination voltage 5/14 V	Illumination voltage 28 V
Plug P1/P2/P3 - Pin 6 (Ill.A)	0...5 V 5...14 V	Ground
Plug P1/P2/P3 - Pin 8 (Ill.B)	Ground	10...28 V

2.6.4. Wiring Diagrams RMU MASTER/SLAVE and Core Modules

2.6.4.1. RMU5000-1: COM – RT3209 /NAV/XPDR – ATC4401, ATC5401

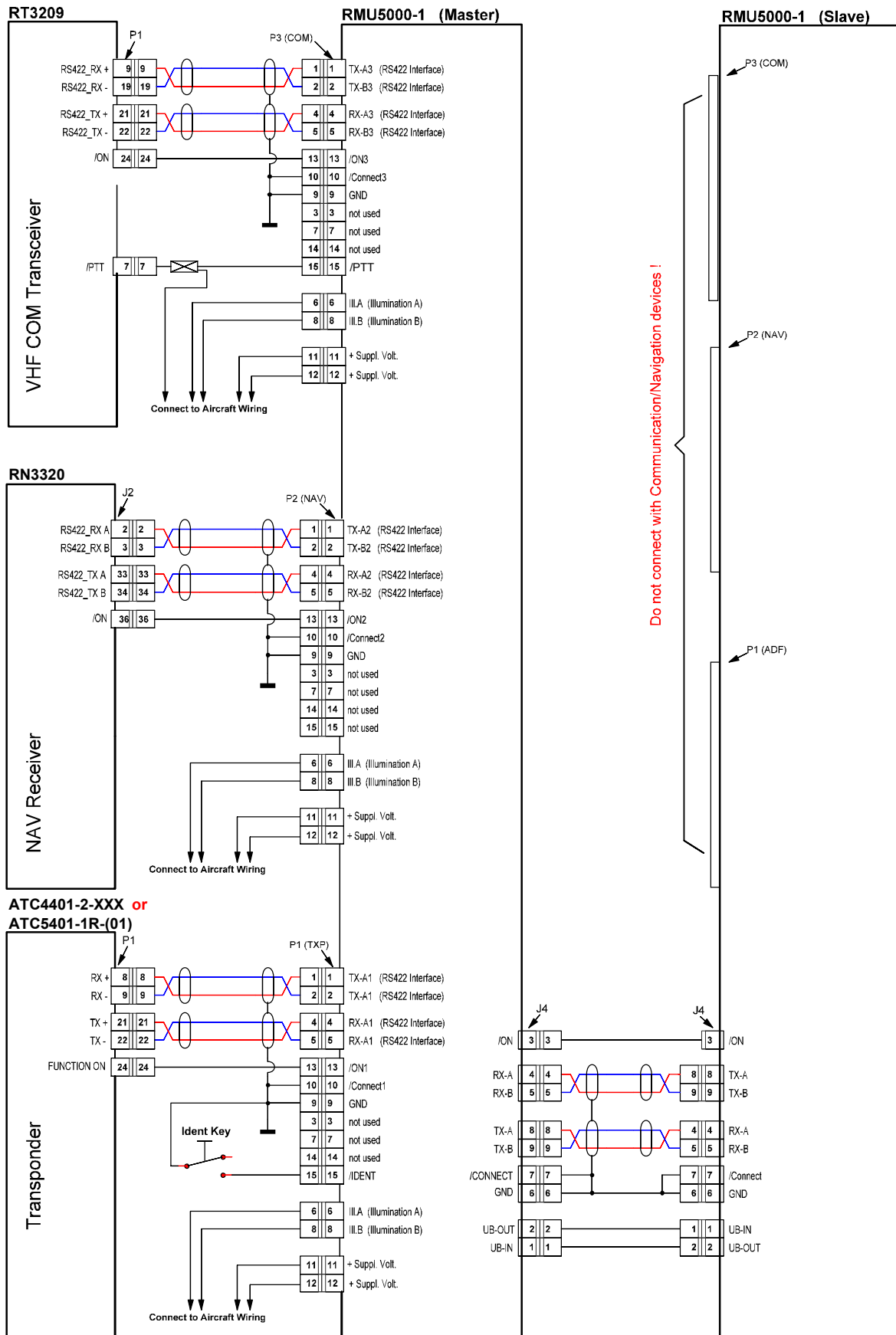

Figure 5: Wiring Diagram RMU5000-1-XXXX (COM – RT3209 /NAV/XPDR – ATC4401, ATC5401)

**2.6.4.2. RMU5000-1: COM – RT6512 /NAV/XPDR – ATC3401**

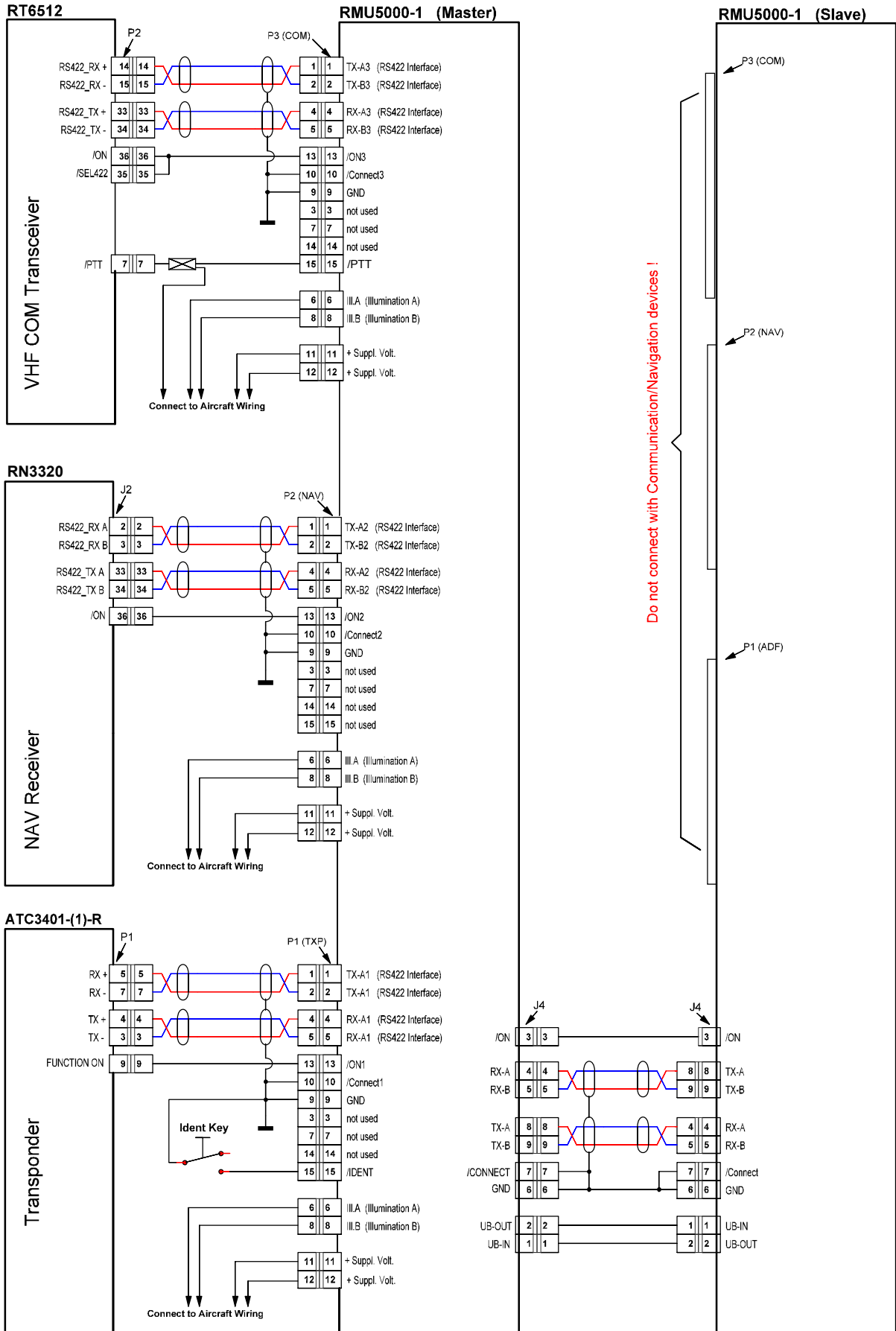

Figure 6: Wiring Diagram RMU5000-1-XXXX (COM – RT6512 /NAV/XPDR – ATC3401)

**2.6.4.3. RMU5000-2: COM – RT5202 /NAV – RN3320 /ADF – RA3502**

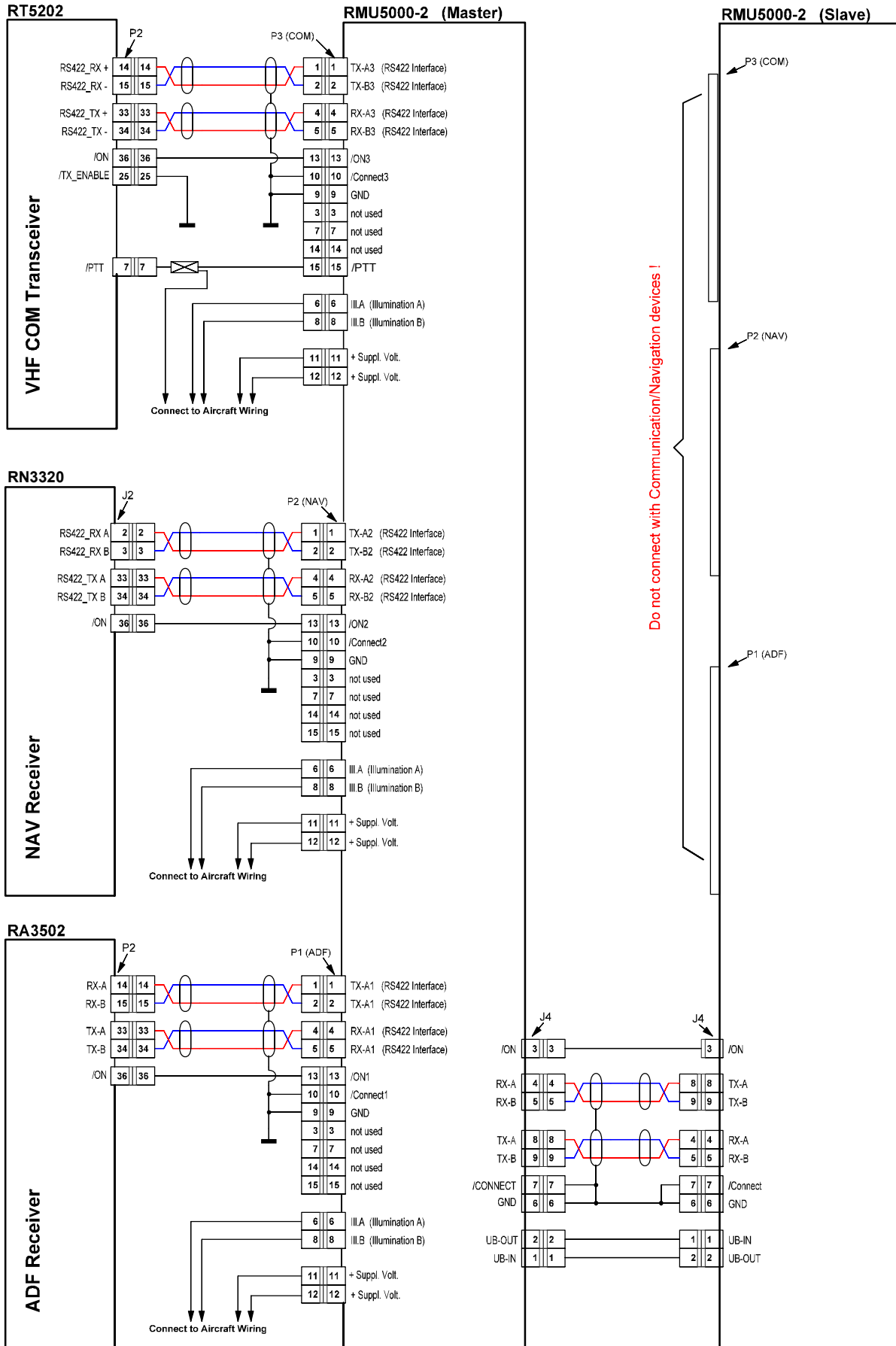

Figure 7: Wiring Diagram RMU5000-2-XXXX (COM – RT5202 /NAV – RN3320 /ADF - RA3502)

## 2.7. Installation Setup

### 2.7.1. Service Mode Menu

Purpose of this menu is RMU and core modules configuration.

**SAFETY INSTRUCTIONS**

This should be done on the ground. Generally, this should not be used during flight.

### 2.7.2. Activation

- Press the SQL and STO/CH keys together (at the end of PBIT) to start the service menu mode.

### 2.7.3. Menu Screen Layout

The menu screen is divided into six parts, as shown:

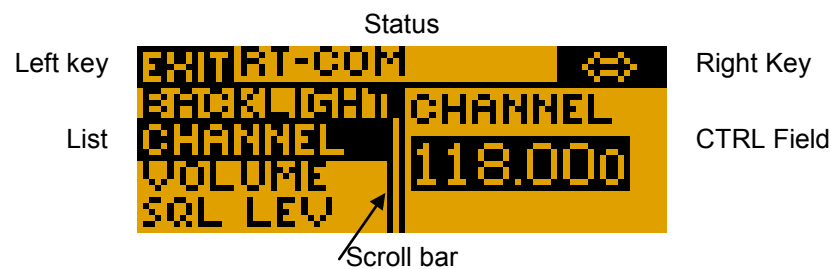

Figure 8: Service Menu (screen layout)

Menu field	Description
Status	Contains information about core module, which currently selected option belongs to. If option belongs to RMU then "RMU5000" will be displayed. If option belongs to e.g. RT5202 / RT6512 then "RT-COM" will be displayed or if there are errors reported then error message appears.
Key left	Contains information about current function of the IDT KEY/ADF TEST KEY. Common function of this key is "EXIT", which can quit the service mode and go to the normal mode of the RMU.
Key right	Contains functions of the EXG KEY. It depends of the selected menu item.
List	Contains a list of menu items. The list can be scrolled to follow user selection.
Control	Is used to display selected item controls, like options values bar graphs etc. By default, each changeable option will be displayed inverted and each read only one none inverted.
Scroll bar	Indicates the position of currently shown items in whole list of menu options. Scroll bar position to follow user selection.

### 2.7.4. Menu Contents

The menu contains options of RMU5000, depending of the connected modules.

### 2.7.5. Select Menu Items

Use the VOL KNOB to select menu items from the list. Selected item is shown "highlighted" (inverted).

- Rotate clockwise to select next option.
- Rotate counter clockwise to select previous option.

### 2.7.6. Illumination Setup Screen

The illumination setup allows an optimum of adaptation for the illumination; the RMU5000 supports an extended setup for the illumination control. A graphical display shows the settings. All changes become active immediately.

## Entering Setup

- Press the SQL/VOICE (B) and STO/CH (F) keys together to start the illumination curve setup. Key details see "Controls and Indications", page 42.

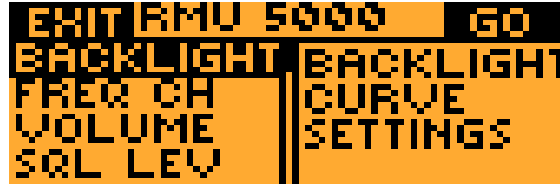

Figure 9: Backlight menu item

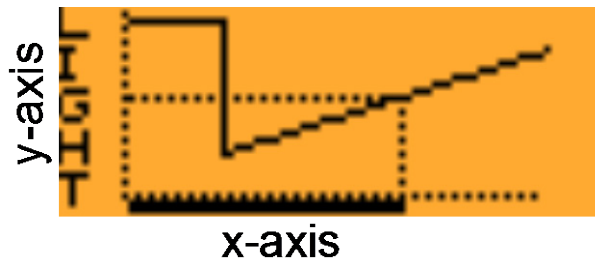

Figure 10: Illumination Setup Screen

The x-axis represents the illumination voltage the y-axis represents the illumination itself. For setting up all of the following illumination points, an illumination voltage must be present and adjustable.

### Dimming Entry Point

This is the voltage point where the dimming starts. If the illumination voltage is under this point, there is no dimming. This will allow permanent illumination if there is no dimming voltage supplied.

Use the VOL KNOB to adjust the value.

The value change is shown in the x-axis.

### Minimum Illumination Point

The minimum illumination point is the point where the dimming starts. This point indicates the lowest illumination.

Use the kHz KNOB to adjust the value:

- Rotate clockwise to increase the value.
- Rotate counter clockwise to decrease the value.

The value change is shown in the y-axis.

Minimum illumination point shall be lower or equal to maximum illumination point. When user increases value of minimum point over maximum point then maximum point shall also be increased to the same value as minimum point. Accelerative change function shall be used.

### Maximum Illumination Point

The maximum illumination point is the 5/14/28 VDC point where the dimming ends. This can be changed on the x-axis from the dimming entry point to 14/28 VDC or down on the y-axis if the x-value reaches the maximum 14/28 VDC. The point represents the highest illumination value.

For 5 VDC illumination, this point is able to be configured for maximum 5 VDC.

Use the MHz KNOB to adjust the value:

- Rotate clockwise to increase the value.
- Rotate counter clockwise to decrease the value.

Allowed range is from minimum illumination point to the full scale. The illumination is a linear approximation function between the minimum illumination point and the maximum illumination point. Accelerative change function shall be used.

The value is modified in the y-axis.

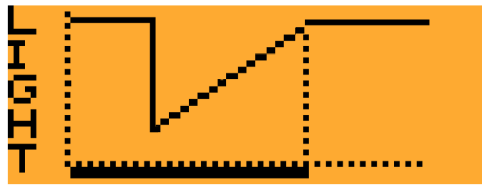

Figure 11: Max. illumination point ( $x < 14/28$  VDC), for example  $x = 5$  V

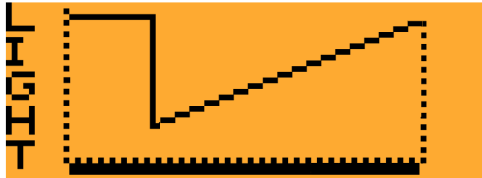

Figure 12: Max. illumination point ( $x = 14/28$  VDC)

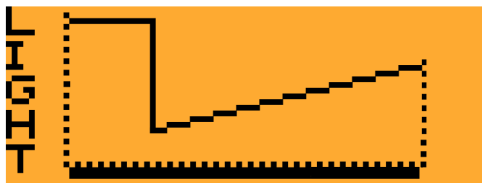

Figure 13: Reduced max. illumination point ( $x = 14/28$  VDC)

### Leaving Illumination Setup

- Press the IDT/ADF TEST key (F) to leave the illumination setup menu.

The RMU5000 will continue with the normal operation. Key details see "Controls and Indications", page 42.

**Blank Page**



### 3. Operating Instructions

#### 3.1. Device Description

The RMU5000 (Radio Management Unit) is part of a radio management system and intended for installation in an aircraft. It serves for the control of up to three remote-controlled core modules.

- The RMU5000-1-XXXX can be operated with the core modules COM, NAV and XPDR.
- The RMU5000-2-XXXX can be operated with the core modules COM, NAV and ADF.

All controls and indicators are located on the front panel.

For details see "User Interface RMU5000-1-XXXX", page 42, "User Interface RMU5000-2-XXXX", page 43.

#### In this chapter you can read about:

3.1. Device Description .....	41
3.1.1. Device Assignment .....	41
3.1.2. Packing, Transport, Storage .....	41
3.1.3. Scope of Delivery .....	41
3.1.4. Type Plate .....	41
3.2. Controls and Indications .....	42
3.2.1. User Interface RMU5000-1-XXXX .....	42
3.2.2. User Interface RMU5000-2-XXXX .....	43
3.2.3. Start-Up .....	44
3.2.4. All Core Modules OFF .....	45
3.3. Operating .....	45
3.3.1. COM Function .....	45
3.3.2. NAV Function .....	48
3.3.3. XPDR Function .....	51
3.3.4. ADF Function .....	55
3.3.5. Menu for RMU5000 .....	59
3.3.6. Menu for RT3209 .....	60
3.3.7. Menu for RT5202/RT6512 .....	63
3.3.8. Tandem Operation .....	69

##### 3.1.1. Device Assignment

This manual is valid for the following devices:

- See "Device Assignment", page 26.

##### 3.1.2. Packing, Transport, Storage

- See "Packaging, Transport, Storage", page 41.

##### 3.1.3. Scope of Delivery

- See "Scope of Delivery", page 26.

##### 3.1.4. Type Plate

- See "Type Plate", page 27.

### 3.2. Controls and Indications

#### 3.2.1. User Interface RMU5000-1-XXXX

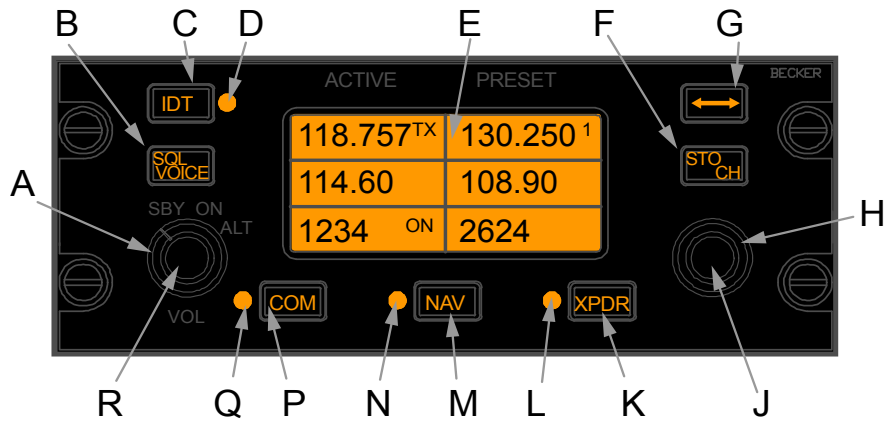

Figure 14: Front panel RMU5000-1-XXXX

	Symbol	Description	Main Function
A	SBY / ON / ALT	Rotary switch with 3 lock positions	Mode switch and mode switch for transponder.
B	SQL / VOICE	Push-button	Self test activation, SQL ON/OFF and VOICE ident switch-over.
C	IDT	Push-button	Transponder IDENT activation.
D	LED	LED	Transponder reply indication and IDENT indication.
E	Display	Graphic Display (dimnable)	Active/Preset frequencies COM/NAV, Preset channel labeling COM/NAV. Code and mode at XPDR and altitude for XPDR. Preset fields: volume level. Active fields: Self Test state.
F	STO/CH	Push-button	Channel selection and store function.
G	↔	Push-button	Exchange the Active/Preset frequencies or code exchange in case of XPDR.
H	Outer switch	Rotary knob, continuously rotatable	Set MHz frequency in COM/NAV function, cursor adjustment in XPDR function.
J	Inner switch	Rotary knob, continuously rotatable	Set kHz frequency in COM/NAV function, Digit adjustment in XPDR function.
K	XPDR	Push-button	Activation and switch on XPDR function or switch off the transponder by pressing >3 seconds.
L	LED	LED	Indicator for XPDR function.
M	NAV	Push-button	Activation and switch on NAV function or switch off the receiver by pressing >3 seconds.
N	LED	LED	Indicator for NAV function.
P	COM	Push-button	Activation and switch on COM function or switch off the transceiver by pressing >3 seconds
Q	LED	LED	Indicator for COM function
R	VOL	Rotary knob, continuously rotatable	Volume adjustment for COM und NAV (VOICE), Level adjustment for service mode settings

### 3.2.2. User Interface RMU5000-2-XXXX

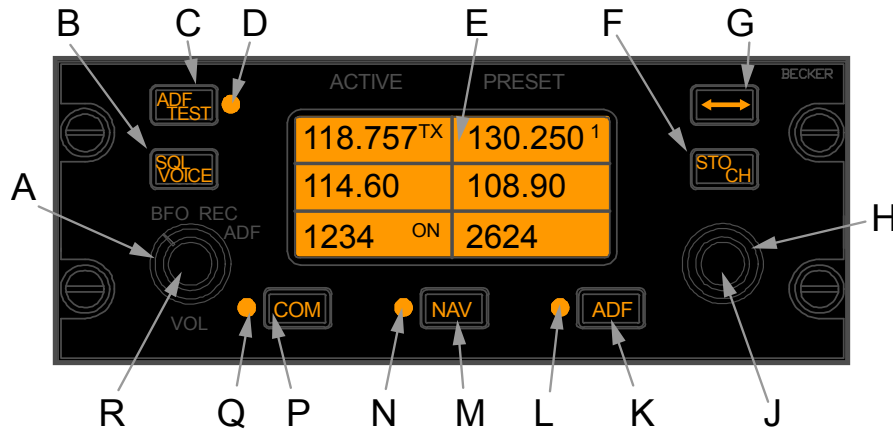

Figure 15: Front panel RMU5000-2-XXXX

	Symbol	Description	Main Function
A	ADF / REC / BFO	Rotary switch with 3 lock positions	Mode switch and mode switch for ADF receiver.
B	SQL / VOICE	Push-button	Self test activation, SQL ON/OFF and VOICE.
C	ADF TEST	Push-button	ADF test activation.
D	LED	LED	IDT Mode indication.
E	Display	Graphic Display (dimnable)	Active/Preset frequencies COM, NAV and ADF. Preset channel labeling COM, NAV and ADF.
F	STO/CH	Push-button	Channel selection and store function.
G	↔	Push-button	Exchange the Active/Preset frequencies.
H	Outer switch	Rotary knob, continuously rotatable	Set MHz frequency in COM/NAV function. Set Hz frequency in ADF function.
J	Inner switch	Rotary knob, continuously rotatable	Set MHz frequency in COM/NAV function. Set Hz frequency in ADF function.
K	ADF	Push-button	Activation and switch on ADF function or switch off the transceiver by pressing >3 seconds.
L	LED	LED	Indicator for ADF function.
M	NAV	Push-button	Activation and switch on NAV function or switch off the receiver by pressing >3 seconds.
N	LED	LED	Indicator for NAV function.
P	COM	Push-button	Activation and switch on COM function or switch off the transceiver by pressing >3 seconds
Q	LED	LED	Indicator for COM function
R	VOL	Rotary knob, continuously rotatable	Volume adjustment for COM, ADF and NAV (VOICE), additionally "VOL" controls SQL level in case of COM and item selection in service mode.

### 3.2.3. Start-Up

- Switch "ON" the device by switching core modules on see:
  - COM function, "ON/OFF Function", page 47.
  - NAV function, "ON/OFF Function", page 50.
  - XPDR function, "ON/OFF Function", page 53.
  - ADF function, "ON/OFF Function", page 57.
- System initialization takes place, i.e. data is transmitted between the RMU5000 and core modules. Total RMU startup time is approx. 5.5 s.
- If the PBIT has detected error(s), "ERROR" appears on the display). Or after finishing of the initialization, the mode which was set before previous power off appears.

#### 3.2.3.1. ROM Test Error

When ROM test detected checksum error message "ERROR: BAD ROM CHECKSUM" is indicated, as shown on following screen:



```
ERROR:  
BAD ROM  
CHECKSUM
```

#### 3.2.3.2. RAM Test Error

When RAM test detected error message "ERROR: RAM TEST FAILED" is indicated, as shown on following screen:



```
ERROR:  
RAM TEST  
FAILED
```

#### 3.2.3.3. NVRAM Test Error

When NVRAM test detected error message "ERROR: BAD ROM CHECKSUM" is indicated, as shown on following screen:



```
ERROR:  
NVRAM TEST  
FAILED
```

#### 3.2.3.4. IBIT (Initiated Build in Test)

The IBIT can be started when all core modules are OFF and then by long pressing of SQL/VOICE keys.

When IBIT is started the test the text "SELFTTEST WAIT..." The test result of IBIT is indicated in the same way like for PBIT.

After successfully passed the display start sequence is as follows:

First 3 s: blank screen, next illumination flash (all pixels bright), then all display negated than back to all pixels bright.

### 3.2.4. All Core Modules OFF

- When all core modules are OFF the RMU5000 will indicate a blank illuminated display.
- Switch "OFF" the device by switching core modules off see:
  - COM function, "ON/OFF Function", page 47.
  - NAV function, "ON/OFF Function", page 50.
  - XPDR function, "ON/OFF Function", page 53.
  - ADF function, "ON/OFF Function", page 57.

## 3.3. Operating

### 3.3.1. COM Function

Press the "COM" key (P) to activate COM function, the LED (Q) lights up.

The left field will indicate the actual operating frequency and the right field of the display line will indicate the standby frequency.



#### 3.3.1.1. Transmit Mode Indication

The TX indication in the display (Active) indicates the transmit mode. During transmission the setting new frequency and starting COM self test are inhibited.

#### 3.3.1.2. Frequency Selector Function

In 25 kHz mode the display indicates two digits after dot (Transceiver RT3209). In 8,33 kHz mode (Transceiver RT5202/RT6512) the display indicates three digits after dot.

The frequency selectors (H, J) are used to select a new standby or channel frequency. The active frequency cannot be modified.

The frequency selectors MHz and kHz have accelerative function, the faster user turns the bigger step he gets.

- Switching of the indicated frequency in 1 MHz steps is carried out using the "outer rotary switch" (H).
- Switching of the indicated frequency in 25 kHz/8.33 kHz steps is carried out using the "inner rotary switch" (J).

#### 3.3.1.3. Exchange Function

Press the "Exchange" key (G) to change between the active frequency and preset frequency. The preset or channel frequency is set using the "MHz" and "kHz frequency selector" switches (H, J).



#### 3.3.1.4. Squelch Function

Press the "SQL/VOICE" key (B) to activate the squelch function. Each press of the "SQL/VOICE" key (B) changes the squelch function from ON to OFF. The right part of the display appears for 3 s after toggling the text:

"SQL OFF" or "SQL" and the bar graph indicating squelch level, both in right part of the display.

Use the VOL KNOB to adjust the squelch level.

- Rotate clockwise to increase the value.
- Rotate counter clockwise to decrease the value.

Changing of the squelch level is indicated on the bar graph. The indication is visible on the display 3 s after last change of squelch level.

When squelch is OFF the indication disappears after 2 s.

118.000	SQL OFF	118.000	SQL ON
108.00	117.95	108.00	117.95
1234 ALT	FL 303	1234 ALT	FL 303

### 3.3.1.5. Channel Function

Press "STO/CH" key (F) to call the channel number. This channel number is the next channel after previously selected. The storage frequency is indicated at the right part of the display section.

Each press of the "STO/CH" key (F) the channel number increases by one and the displayed frequency changes to the proper frequency. The indication of memory channel number disappears immediately, when changes preset frequency by selection or exchanging.

131.100	128.425 <sup>9</sup>
108.00	117.95
1234 ALT	FL 303

Example for channel 9

### 3.3.1.6. Store Function

For storage a frequency:

- Select a channel number where the new preset frequency shall be stored.
- Select a new frequency with the "inner and outer rotary switches" (H, J).
- Press the "STO/CH" key (F) until the channel number is not flashing . The channel indication is displayed until the preset frequency is manually changed with the frequency selector (H, J). Up to 9 COM channels can be stored.

### 3.3.1.7. Volume Adjustment

The volume of the COM module can be adjusted by turning the "inner rotary switch" (R). The volume rotary switch has accelerative function too. The indication of the volume adjustment will be done automatically, at the right part of the display instead of the preset frequency, while adjusting.

If no adjustment is performed within 2 s, the frequency will be displayed again!

Following screens are displayed for lowest/max. volume level:

118.000	MUTE	118.000	██████████
108.00	117.95	108.00	117.95
1234 ALT	FL 303	1234 ALT	FL 303

Lowest volume

Maximum volume

All other values between minimum and maximum are displayed as a bar graph.

118.000	██████████
108.00	117.95
1234 ALT	FL 303



**3.3.1.8. ON/OFF Function**

- Press the "COM" key (P) for longer than 3 s.
- The COM module will be switched OFF.
- The left part of the display shows the text "OFF".

OFF	
108.00	117.95 S
1234 ALT	FL 305

- Press the "COM" key (P).
- The COM module will be switched ON and initialised again.
- The display shows the text "WAIT ..." while initialising.
- After initialising the RMU5000 goes to normal operation.

WAIT...	
108.00	117.95 S
1234 ALT	FL 305

**3.3.1.9. Test Function**

- Press "SQL / VOICE" key (B) longer than 3 s to activate the self test.
- The left part of the display shows successively the text: "Test ...".
- Afterwards the RMU goes back to COM mode.
- In case of an error this indication shall be displayed permanently in the left part of the display line with the word «FAILURE».

During the test the following screen will be displayed:

<b>TEST...</b>	<b>136.975</b>
<b>108.00</b>	<b>117.95</b>
<b>1234 ALT</b>	<b>FL 303</b>

**3.3.1.10. Transmit/Receive Mode**

- Set the frequency to the local ground station.
- Operate the transmit button and call the ground station.
- Hold the microphone close to the lips for optimum speech transmission.
- Set the correct reception volume using the "VOL control" (R) whilst the ground station is answering.

Note:

- The TX indication in the display (E) indicates the transmit mode.
- During transmission a protective circuit prevents a frequency change and activating test mode.
- If there is acoustic feedback during transmission the sidetone volume on the VHF transceiver must be turned down.

### 3.3.1.11. Jamming of Transmit Button

The VHF transceiver system is fitted with a protective circuit to protect against damage in case of jamming of the transmit button or a short circuit on the key line. For continuous transmissions exceeding three minutes the protective circuit automatically switches from transmission to reception. This avoids the switched channel being blocked.

**SAFETY INSTRUCTIONS**

In order to continue transmitting even with the transmit button jammed, the VHF transceiver must be switched off and then back on again. After that the VHF transceiver then continues to operate in the transmit mode for a further three minutes.

### 3.3.2. NAV Function

The indications for NAV mode will be shown at the middle line of the display.

- Press the "NAV" key (M) to activate the NAV function.
- The associate LED (N) will light up.
- The left field indicates the actual operating frequency and the right field of the display indicates the standby frequency.

If the RMU5000 shows at the left part of the display the text "FAILURE", the NAV module has a failure or the communication between the NAV module and the RMU5000 has a error.

#### 3.3.2.1. Frequency Selector Function

- The frequency selectors (H, J) shall be used to select a new standby or channel frequency. The active frequency shall not be modified.
- Switching of the indicated frequency in 1 MHz steps is carried out using the "outer rotary switch" (H).
- Switching of the indicated frequency in 25 kHz/8.33 kHz steps is carried out using the "inner rotary switch" (J).

#### 3.3.2.2. Exchange Function

- Press the "Exchange" key (G) to change between the active frequency and preset frequency.
- The preset or channel frequency is set using the MHz and kHz frequency selector switches (H, J).



#### 3.3.2.3. Voice Function

- Press the "SQL / VOICE" key (B) to activate the voice function.
- The right part of the display shows the text "Voice".
  - If no settings are carried out within about 2 s the voice mode finishes automatically!
- Press the "SQL / VOICE" key (B) to deactivate the voice function.
- The right part of the display shows the text "NAV IDT".
  - If no settings are carried out within about 2 s the voice mode finishes automatically!





**3.3.2.4. Test Function**

- Press "SQL / VOICE" key (B) longer than 3 s to activate the self test.
- The test is being performed as long as user holds SQL/VOICE key pressed.
- The left part of the display shows successively the text: "Test...".
- Afterwards the RMU5000 goes back to NAV mode.
- In case of an error this indication shall be displayed permanent in the left part of the display line with the word «FAILURE».

During the test the following screen shall be displayed :



**3.3.2.5. Channel Function**

- Press "STO/CH" key (F) to call the channel mode. This channel number is the next channel after previously selected.
- The preset frequency indication at the right part of the display.
- Each pressing of the "STO/CH" key (F) the channel number increased by one and the frequency indication changes to the proper frequency. The indication of memory channel number disappears immediately, when changes preset frequency by selection or exchanging.

An example for channel 9:



**3.3.2.6. Store Function**

- For storage of a frequency select a channel number where a new preset frequency shall be stored.
- Select a new frequency with the "inner and outer rotary switches" (H, J).
- Press the "STO/CH" key (F) until the channel number flashes 3 times. The channel indication is displayed until the preset frequency is manually changed with the "frequency selector switch" (H, J).

Up to 9 NAV channels can be stored.

**3.3.2.7. ON/OFF Function**

- Press the "NAV" key (M) for longer than 3 s. The NAV module will be switched OFF.
- The left part of the display shows the text "OFF"



- Press the "NAV" key (M). The NAV module will be switched on and initialised again.
- The display shows the text "WAIT ..." while initialising.
- After initialising the RMU5000 goes to normal operation.



**3.3.2.8. Volume Adjustment**

- The volume of the NAV module can be adjusted by turning the "inner rotary switch" (R). The volume rotary switch has accelerative function.
- The indication of the volume adjustment will be done automatically, at the right part of the display instead of the preset frequency, while adjusting.
  - If no adjustment is carried out more than 2 s, the frequency will be displayed again!

Following screens are displayed for lowest/max. volumes level:



Lowest volume



Maximum volume

All other values between minimum and maximum are displayed as a bar graph.



**3.3.2.9. VOR Mode**

- Set the frequency to the required VOR station.
- To monitor the identification signal, press the "SQL / VOICE" key (B). Monitor the identification signal and compare it with the set identification signal of the required VOR station. Adjust the volume using the "VOL control" (R).
- If an adequate VOR signal enables a safe bearing to be established, the vertical needle deflects on the indicator and the VOR/LOC flag disappears from the field of view.
- Rotate the omni-bearing selector (OBS) on the indicator until the TO/FROM display indicates TO and the vertical needle has settled in the mid position. The heading indication then indicates the magnetic course to the VOR station.
- Course deviations during the approach are indicated in the direction of correction by the vertical needle (course correction in the direction of the needle deflection).
- When overflying the VOR station, the TO/FROM indicator moves from TO to FROM. If the flight is continued on the same heading, the course indication shows the magnetic position line of the VOR station which the aircraft is approaching, with the vertical needle in the mid position.

**3.3.2.10. LOC Mode**

- Set the frequency to a required localizer frequency.
- Switch on the VOR identification with button (C). Monitor the morse identification signal and compare it with the set identification signal of the required localizer.
- The vertical needle (command needle) on the indicator deflects during the approach to the localizer in the direction in which the course is to be corrected in order to obtain the correct landing course. A mid position of the needle means that the aircraft is on the correct line for landing

**3.3.2.11. GS Mode**

- Set the frequency to a localizer frequency.
- Switch on the VOR identification with button (C). Monitor the morse identification signal and compare it with the set identification signal.
- If a glide path signal of sufficient strength is present, the GS warning flag disappears from the field of view.
- The GS needle (horizontal command needle) on the indicator deflects during the approach in the direction in which the flight level has to be corrected in order to obtain the specified glide path. A mid position of the needle means that the aircraft is on the glide path

**3.3.3. XPDR Function**

- The indications for XPDR mode will be shown at the bottom line of the display.
- Press the "XPDR" key (K) to activate XPDR function, the associate LED (L) will light up.
- The left field indicates the actual transponder code and the right field indicates the standby transponder code or the flight level.
- If the RMU5000 shows at the left part of the display the text "FAILURE", the XPDR module has a failure or the communication between the XPDR module and the RMU5000 has an error.

**3.3.3.1. Exchange Function**

Pressing the "Exchange" key (G) changes over between the preselected transponder code at the active transponder code.

**3.3.3.2. Test Function**

- Press "SQL/VOICE" key (B) for longer than 3 seconds to activate the self test.
- The left part of the display shows successively the text: "Test...".
- Afterwards the RMU5000 goes back to XPDR mode.
  - In case of an error this indication shall be displayed permanent in the left part of the display line with the word «FAILURE».

**3.3.3.3. Code Selector Function**

- Using the "frequency selector" (H, J), set the new 4-digit code.
- Using the "outer rotary switch" (H) move the cursor to the particular digit. Digits 0 to 7 can be set using the "inner rotary switch" (J).
- If "outer rotary switch" (H) is turned clockwise/counter clockwise, the cursor is moved one position left/right.
- If "inner rotary switch" (J) is turned clockwise the selected digit is increment or counter clockwise, the selected digit is decrement.

All frequency selector switches have roll over function.

Following screens are displayed the altering of the first and third digit.

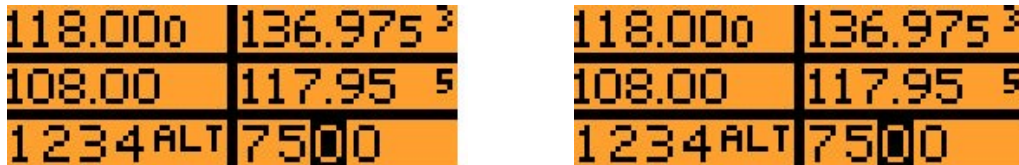

**3.3.3.4. Channel VFR Function**

- Press the "XPDR" key (K) to activate XPDR mode.
- Press the "STO/CH" key (F) to select the channel / VFR function.
- The right field of the display shows the last memorised VFR code and additionally the text "VFR" ok.
- The VFR code changes to active code and the LED for transponder mode goes off.
- Press the "Exchange" key (G), the RMU5000 change to the last active mode (COM, NAV) the associated LED (Q, N) light up.

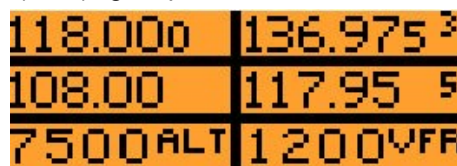

**3.3.3.5. Store VFR Function**

- Press the "XPDR" key (K) to activate XPDR mode.
- Change the VFR code with the "inner and outer rotary switch" (H, J) right.
- Press the "STO/CH" key (F) until the plain text "VFR" flashes 4 times.
- Press the "COM" key (P) or "NAV" key (M) to quit XPDR mode.



Altering

Storage

**3.3.3.6. ON/OFF Function**

- Press the "XPDR" key (K) longer than 3 s to switch OFF the XPDR module.
- The left field of the display shows the text "OFF".
- Press the "XPDR" key (K) to switch ON and initialised again.
- The text "WAIT ..." is shown while initialising.
- After initialising the RMU5000 goes to normal operation.

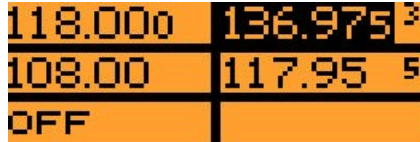

XPDR module - OFF

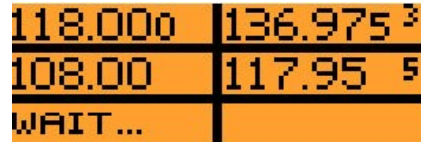

XPDR module - initialising

**3.3.3.7. Warm-Up Function**

**SAFETY INSTRUCTIONS**

ATC3401

The LED "SBY" flashes for approx.30 seconds while warming up the transponder.

**SAFETY INSTRUCTIONS**

ATC4401

The solid state transponder needs no warm-up time.

A blind encoder needs a warm-up time (sometimes a several minutes) when connected. In this time the LED "SBY" flashes

**SAFETY INSTRUCTIONS**

- If XPDR function is activated within the first 30 seconds after power on, the transponder is in the warm up phase. The transponder cannot transmit during this time, and "—SBY" appears in the display with LED "SBY" blinking.
- After the warm up phase has elapsed, the SBY indication stops flashing and the transponder switches to the mode set on the "mode switch" (A). The transponder is ready.

**3.3.3.8. Flight Operation in the ON Mode**

- The transponder remains switched in the standby mode until requested from the ground station (ATC) to send a code. e.g. "squawk alpha 1234". Set the 4-digit code see "Code Selector Function", page 52.

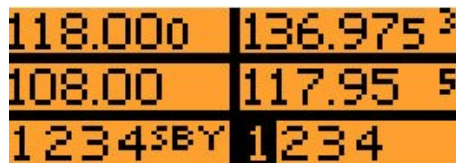

**SAFETY INSTRUCTIONS**

Do not set a code with 75XX / 76XX / 77XX. These special codes are reserved for emergencies. See "Special Codes for Air Emergency", page 54.



- Press the "XPDR" key (K) to activate XPDR function.
- Whilst settings are taking place, the transmission branch of the transponder is inhibited to prevent unintentional transmission.
- Set "rotary switch" (A) from SBY to ON.
- The ON indication appears in the display and the transponder immediately replies with the set code. The LED (D) signals the transponder replies.

118.000	136.975 <sup>3</sup>
108.00	117.95 <sup>5</sup>
1234 ON	MODE A

Following screen shows the ON mode indication during code change:

118.000	136.975 <sup>3</sup>
108.00	117.95 <sup>5</sup>
1234 ON	1234

- After a "squawk ident" request from ATC, press the "IDT" key (C). This transmits an additional special pulse (SPI) for approximately 25 s which enables the aircraft to be clearly identified on the radar screen of the controller.
- The last used code is stored in any case and is also activated when the transponder is switched on.

### 3.3.3.9. *Flight Operation in the ALT Mode*

**Note:** This only makes sense if the transponder is connected to a coding altimeter. If not, tell ATC that you do not have a mode C ("mode charlie not available").

- If ATC requests the transmission of "alpha/charlie or "charlie", switch the transponder to ALT using "rotary switch" (A). The ALT indication appears in the display.
- The transponder replies using the code and in response to mode C requests it transmits the flight level of the aircraft to ATC.
- The LED (D) indicates transponder replies.
- The display shows the flight level which is encoded by the altimeter: "FL xxx".

118.000	136.975 <sup>3</sup>
108.00	117.95 <sup>5</sup>
1234 ALT	FL 303

Following screen shows the ALT mode indication during code change:

118.000	136.975 <sup>3</sup>
108.00	117.95 <sup>5</sup>
1234 ALT	1234

### 3.3.3.10. *Special Codes for Air Emergency*

Special codes, which depend on the type of incident, are stipulated for certain air emergencies:

- 7500 Hijacking of the aircraft,
- 7600 Failure of radio communication,
- 7700 Emergency on board which constitutes an immediate danger to the aircraft.

The code evaluation devices of the radar systems automatically alarm the controllers at the radar screens immediately, if one of these special codes is received.

Unintentional transmission of an emergency code is prevented by inhibiting in that the transponder replies whilst the code is being set. This applies particularly where the new code is being set in ON or

ALT modes. Also if a special code is called up, no transponder reply takes place during the period in which the previous code can be reactivated (approx. 3 s).

This is avoided by the edition of a "SBY code".

<b>ACT</b>	<b>SBY</b>
<b>1 2 3 4</b>	<b><u>1</u> 2 3 4</b>

During the edition, the transponder replies with the ACT code, the SBY becomes active after pressing "Exchange" key (G) or "IDT" key (C).

**3.3.3.11. RMU Switch-Off**

The COM, NAV, and XPDR functions (inclusive core modules) can be switched-off individually by pressing the corresponding buttons (P, M, K); the accessory LEDs (Q, N, L) will then go off.

**3.3.4. ADF Function**

- Press "ADF" key (K) to activate the ADF function.
- The associated LED (L) lights up.
- The indications for ADF mode will be shown at the bottom line of the display.
- The left field indicates the actual operating frequency and the right field of the display indicates the standby frequency.
  - If the RMU5000 shows the text "FAILURE" at the left part of the display, the ADF module has a failure or the communication between the ADF module and the RMU5000 has an error.

**3.3.4.1. Frequency Selector Function**

- The "frequency selector switches" (H, J) are used to select a new standby or channel frequency.
- The active frequency cannot be altered.
- Switching of the indicated frequency in 10 kHz steps is carried out using the "outer rotary switch" (H).
- Switching of the indicated frequency in 500 Hz steps is carried out using the "inner rotary switch" (J).
- Both rotary switches have a roll-over function, allowing to going from the highest frequency to the lowest frequency within one step.

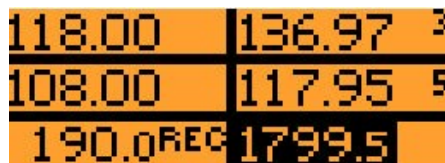

**3.3.4.2. Exchange Function**

- Press the "Exchange" key (G) to change over between the active frequency and preset frequency.
- Press the "frequency selector switches" (H, J) to set the preset or channel frequency.

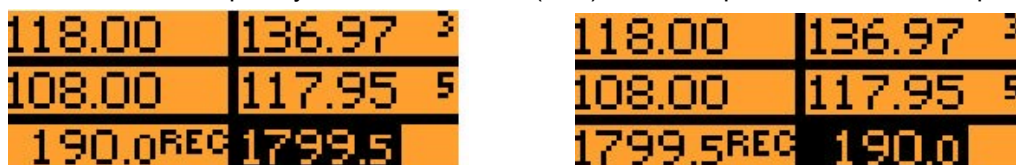

**3.3.4.3. Test Function**

- Press the "SQL / VOICE" key (B) longer than 3 s to activate the self test.
- The left part of the display shows successively the text: "Test..." and go back to normal operation.
  - In case of an error the display indicated permanent in the left part of the display line with the word «FAILURE».

**3.3.4.4. ADF Test Function**

- Press the "ADF/ TEST" key (C) >5 s. During this time the ADF indicator go to the 90 degree position.
- After 5 s the ADF will return to ADF mode.

Both test are performed as long as user holds key (SQL/VOICE or ADF TEST) pressed.

**3.3.4.5. Channel Function**

- Press "STO/CH" key (F) to call the channel function. The displayed channel number is the next channel after previously selected.
- The preset frequency is displayed at the right part of the display.
- Each pressing of the "STO/CH" key (F) the channel number increased by one and the frequency indication changes to the proper frequency. The Indication of memory channel number disappears immediately, when changes preset frequency by selection or exchanging.

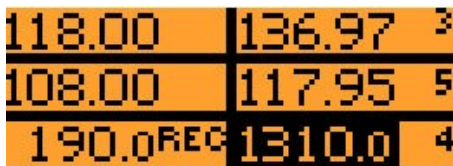

Channel indication in REC mode



Channel indication in BFO mode

**3.3.4.6. Store Function**

- For storage of a frequency select a channel number where a new preset frequency shall be stored.
- Select a new frequency with the "inner and outer rotary switches" (H, J).
- Press the "STO/CH" key (F) until the channel number flashes 4 times. The channel indication is displayed until the preset frequency is manually changed with the "frequency selector switch" (H, J).

Up to 9 ADF channels can be stored.



**3.3.4.7. ON/OFF Function**

- Press the "ADF" key (M) for longer than 3 s. The ADF module will be switched OFF.
- The left part of the display shows the text "OFF"

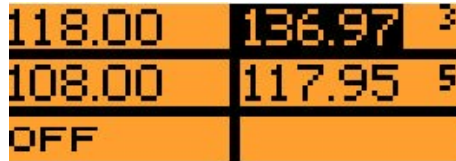

- Press the "ADF" key (M). The ADF module will be switched on and initialised again.
- The display shows the text "WAIT ..." while initialising.
- After initialising the RMU5000 goes to normal operation.

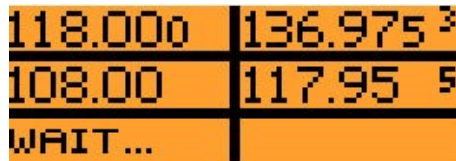

**3.3.4.8. Volume Adjustment**

- The volume of the ADF module can be adjusted by turning the "inner rotary switch" (R). The volume rotary switch has accelerative function.
- The indication of the volume adjustment will be done automatically, at the right part of the display instead of the preset frequency, while adjusting.
- If no adjustment is carried out more than 2 s, the frequency will be displayed again!

Following screens are displayed for lowest/max. volume level:



Lowest volume



Maximum volume

All other values between minimum and maximum are displayed as a bar graph.



**3.3.4.9. Operating Mode**

- The operation mode will be changed with the rotary switch "BFO / REC / ADF" (A) outer 3-position knob).
- The display shows, in addition to the active frequency, the text "BFO", "REC", "ADF".

**3.3.4.10. Receive Mode**

- Turn the "outer rotary switch" (A) to position "REC".
- In this mode the left side of the display indicate «REC» and the right side of the display indicate the preset frequency.
- The RMU5000 switch the core module to the REC operation mode.

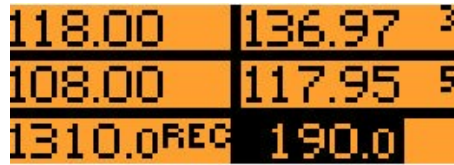

**3.3.4.11. ADF Mode**

- Turn the "outer rotary switch" (A) to position "ADF".
- In this mode the left side of the display indicate «ADF» and the right side of the display shall indicate the preset frequency.
- The RMU5000 switch the core module to the ADF operation mode.



**3.3.4.12. BFO Mode**

- Turn the "outer rotary switch" (A) to position "BFO".
- In this mode the left side of the display indicates «BFO» and the right side of the display indicate the preset frequency.
- The RMU5000 switch the core module to the BFO operation mode.

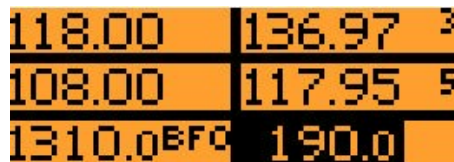

**3.3.4.13. Emergency Mode**

- Turn the kHz frequency selector (J) on the end of selectable frequencies (1799.5 kHz) one step upwards. The Emergency frequency 2182 kHz appears in the right display.
- Press "Exchange" key (G). In the left display appears the emergency frequency and in the right display appears the tuning offset.
- Change the tuning offset in steps of 500 Hz upwards or downwards. The RMU5000 send the tuning offset immediately to ADF core module, without additional user action. The range of IMD offset is max. ±5 kHz.
- Press the " Exchange" key (G) to go back to normal receive operation.
- The active frequency is restored as it was before entering emergency mode.

**3.3.4.14. COM / NAV Function**

Operating instructions for COM see, "COM Function" page 45.

Operating instructions for NAV see "NAV Function", page 48.

**3.3.4.15. REC / ADF / BFO Function**

- Set the HDG setting on the indicator so that the 0°/360° scale appears.
- Set the frequency of the required NDB station and monitor the identification signal. For A1 identification the BFO mode must be selected (set the mode switch (A) to BFO).
- After checking the identification signal, select the ADF mode (set the "mode switch" (A) to ADF).
- The needle moves in the direction of the set NDB station.
- Depending on the flight procedure, set the compass heading using the HDG setting.

**3.3.4.16. Service Mode**

Purpose of this menu is RMU and core modules configuration.

**SAFETY INSTRUCTIONS**

This should be done on the ground. Generally, this should not be used during flight.

Operating instructions for Service mode see "Service Mode Menu", page 37.

**3.3.5. Menu for RMU5000**

**3.3.5.1. Software Version and Release**

- Use the "VOL knob" (R) to select in the menu list "SOFT VER".
- In the CTRL FIELD appears "Software version" and value of serial number with leading zeros.
- This is indication value is read only.

<b>EXIT RMU5000</b>	
<b>SOFT VER</b>	<b>V1.00</b>
<b>RMU SN</b>	<b>RLS. DATE</b>
<b>RMU TYPE</b>	<b>02.04.01</b>
<b>FIN</b>	

**3.3.5.2. Device Serial Number**

- Use the "VOL knob" (R) to select in the menu list "RMU SN".
- In the CTRL FIELD appears "RMU Serial number". This is serial number is read only.

<b>EXIT RMU5000</b>	
<b>SOFT VER</b>	<b>SERIAL</b>
<b>RMU SN</b>	<b>NUMBER</b>
<b>RMU TYPE</b>	<b>0001</b>
<b>FIN</b>	

**3.3.5.3. Device Type (Variants)**

- Use the "VOL knob" (R) to select in the menu list "RMU TYPE".
- In the CTRL FIELD appears "RMU VARIANTS". This is read only.

<b>EXIT RMU5000</b>	
<b>SOFT VER</b>	<b>RMU 5000-</b>
<b>RMU SN</b>	<b>-1-1110</b>
<b>RMU TYPE</b>	<b>MS000</b>
<b>FIN</b>	

**3.3.5.4. Factory identification number (FIN)**

- Use the "VOL knob" (R) to select in the menu list "FIN".
- In the CTRL FIELD appears "FIN". This is serial number is read only.



**3.3.5.5. Leave the Service Mode**

- Press the "IDT" key (C).

**3.3.6. Menu for RT3209**

**3.3.6.1. Frequency Channel**

- Use the "VOL knob" (R) to select menu list step. The following display appears (setup operational parameters for the RT3209).
- Each press of the "STO/CH" key (F) the channel number increases by one and the frequency indication changes to the proper frequency.
- For storage of a frequency, select a channel number where a new preset frequency shall be stored.
- Select a new frequency with the inner and "outer rotary switches" (H, J).
- Press the "STO/CH" key (F) until the channel number flashes 3 times.

Up to 9 COM channels can be stored.



**3.3.6.2. Volume**

- Use the "VOL knob" (R) to select next menu list step.
- The volume level can be adjusted using the "kHz knob" (J) and "MHz knob" (H).
  - Rotate clockwise to increase the value in steps of 1 dB/10 dB.
  - Rotate counter clockwise to decrease the value in steps of 1 dB/10 dB.



**3.3.6.3. Squelch Level (SQL)**

- Use the "VOL knob" (R) to select menu SQUELCH.
- Each press of the "SQL/VOICE" key (B) changes the squelch function from ON to OFF.
- The squelch level can be adjusted using the "kHz knob" (J) and "MHz knob" (H).
  - Rotate clockwise to increase the value in steps of 1 dB/10 dB.
  - Rotate counter clockwise to decrease the value in steps of 1 dB/10 dB.

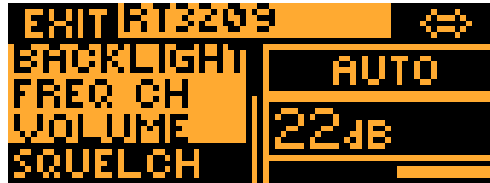

**3.3.6.4. Sidetone Level**

- Use the "VOL knob" (R) to select next menu list step.
- The sidetone level can be adjusted using the "kHz knob" (J) and "MHz knob" (H).
  - Rotate clockwise to increase the value in steps of 1 dB/10 dB.
  - Rotate counter clockwise to decrease the value in steps of 1 dB/10 dB.

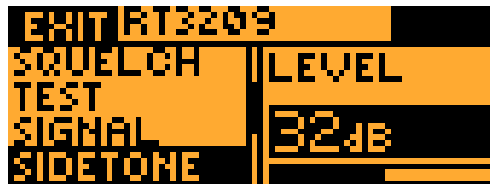

**3.3.6.5. Auxiliary Input Level (AUX)**

- Use the "VOL knob" (R) to select next menu list step.
- The auxiliary input can be adjusted using the "kHz knob" (J) and "MHz knob" (H).
  - Rotate clockwise to increase the value in steps of 1 dB/10 dB.
  - Rotate counter clockwise to decrease the value in steps of 1 dB/10 dB.

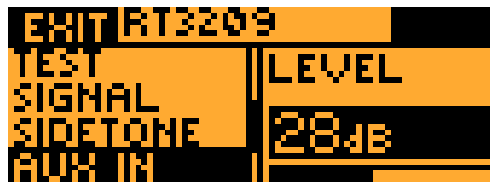

**3.3.6.6. Intercom Input Level**

- Use the "VOL knob" (R) to select next menu list step.
- The intercom input can be adjusted using the "kHz knob" (J) and "MHz knob" (H).
  - Rotate clockwise to increase the value in steps of 1 dB/10 dB.
  - Rotate counter clockwise to decrease the value in steps of 1 dB/10 dB.



**3.3.6.7. Dynamic Mike Level (DMC)**

- Use the "VOL knob" (R) to select next menu list step.
- The dynamic mike level can be adjusted using the "kHz knob" (J) and "MHz knob" (H).
  - Rotate clockwise to increase the value in steps of 1 dB/10 dB.
  - Rotate counter clockwise to decrease the value in steps of 1 dB/10 dB.

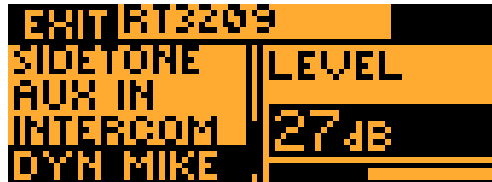

**3.3.6.8. Internal Speaker Settings**

- Use the "VOL knob" (R) to select next menu list step.
- Each press of the "Exchange" key (G) switch the external speaker ON or OFF.



**3.3.6.9. Self test**

- Use the "VOL knob" (R) to select next menu list step.
- Press the "Exchange" key (G). In the CTRL FIELD "SELFTEST" appears "WAIT"->TEST. When the self test in RT3209 is finished the display appears "TEST OK" for 2 s.
- Then "READY" is shown in the display again.



**3.3.6.10. Device Serial Number**

- Use the "VOL knob" (R) to select in the menu list "DECICE SN".
- In the CTRL FIELD appears the "SERIAL NUMBER" and value of serial number with leading zeros.
- This is indication value is read only.

### 3.3.6.11. Recall Settings

- Use the "VOL knob" (R) to select in the menu list "RECALL".
- Press the "Exchange" key (G) until in the CTRL FIELD appears "CONFIRM" with two steps.
- "NO" and "YES". Selected step is highlighted.
- Select "YES", or "NO" with the "kHz knob" clockwise or counter clockwise rotation.
- If "NO" is selected and press the "Exchange" key (G), then it go back to item recall settings.
- If "YES" is selected and press the "Exchange" key (G), then are set by the factory values for service settings.



### 3.3.7. Menu for RT5202/RT6512

#### 3.3.7.1. Frequency Channel

- Use the "VOL knob" (R) to select menu list step.
- Select a new frequency with the "inner (kHz)" and "outer rotary switches" (MHz) (H, J).

The VHF transceiver is always ready to receive and transmit on the selected frequency.

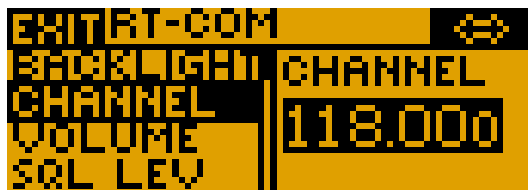

#### 3.3.7.2. Volume Level

- Use the "VOL knob" (R) to select menu list "VOLUME".
- Volume level change is displayed at the top of CTRL FIELD.
- "LOCKED" or "ADJUST" is displayed at the top of CTRL FIELD.
- When indicated "ADJUST" in the RIGHT KEY field, than the volume level can be changed.
- When indicated "LOCKED" it is read only setting.
- Select the function using the "Exchange" key (G).
- The volume level can be adjusted using the "kHz knob" (J) and "MHz knob" (H).
  - Rotate clockwise to increase the value in steps of 0.1 dB/2 dB.
  - Rotate counter clockwise to decrease the value in steps of 0.1 dB/2 dB.

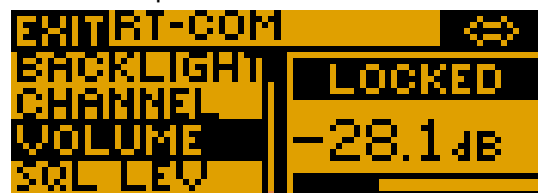
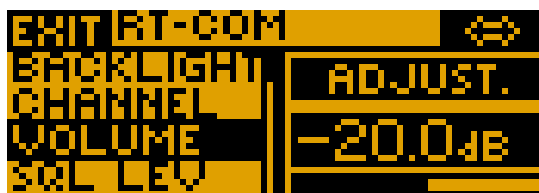

### 3.3.7.3. Squelch Level

- Use the "VOL knob" (R) to select menu list "SQL LEV".  
 Squelch level change is displayed at the top of CTRL FIELD.
- "ON" or "OFF" is displayed at the top of CTRL FIELD.
- When indicated "ADJUST" than the squelch level can be changed.
- When indicated "LOCKED" it is read only setting.
- Select the function using the "Exchange" key (G).
- The squelch level can be adjusted using the "kHz knob" (J) and "MHz knob" (H).
  - Rotate clockwise to increase the value in steps of 0.1 dB/1 dB.
  - Rotate counter clockwise to decrease the value in steps of 0.1 dB/1 dB.

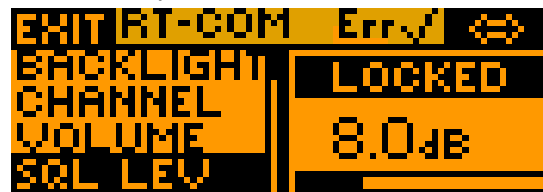
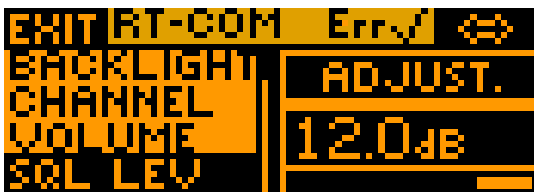

### 3.3.7.4. Sidetone Level

- Use the "VOL knob" (R) to select next menu list step.
- Sidetone level change is displayed at the top of CTRL FIELD.
- The service mode switch in RT5202/RT6512 must be set to 1 otherwise its only indication.
- "OFF" or "ON" is displayed at the top of CTRL FIELD.
- When indicated "ON" than the sidetone level can be changed.
- When indicated "LOCKED" it is read only setting.
- Select the function using the "Exchange" key (G).
- The sidetone level can be adjusted using the "kHz knob" (J) and "MHz knob" (H).
  - Rotate clockwise to increase the value in steps of 0.1 dB/2 dB.
  - Rotate counter clockwise to decrease the value in steps of 0.1 dB/2 dB.



### 3.3.7.5. Modulation Limiting Threshold

- Use the "VOL knob" (R) to select next menu list step.
- The CTRL FIELD contain two bar graphs and value of mode.
- The service mode switch in RT5202/RT6512 must be set to 1 otherwise its only indication.
- The top line indicated mike peak level (bar graph) in the range from -31 dB to -5 dB. Second line indicated modulation limiting threshold (bar graph) in its range in the bottom line indicated the value.
- The level can be adjusted using the "kHz knob" (J) and "MHz knob" (H).
  - Rotate clockwise to increase the value in steps of 0.1 dB/1 dB.
  - Rotate counter clockwise to decrease the value in steps of 0.1 dB/1 dB.

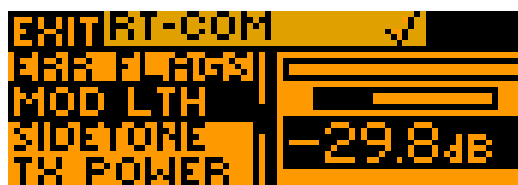



**3.3.7.6. OCXO Frequency Calibration**

- Use the "VOL knob" (R) to select next menu list step.
- The CTRL FIELD contain "CALIBR.", value and bar graph.
- The service mode switch in RT5202/RT6512 must be set to 1 otherwise its only indication.
- The level can be adjusted using the "kHz knob" (J) and "MHz knob" (H).
  - Rotate clockwise to increase the value in steps of 1 or 10.
  - Rotate counter clockwise to decrease the value in steps of 1 or 10.



**3.3.7.7. RX AF AGC Limiting Threshold**

- Use the "VOL knob" (R) to select next menu list step.
- The CTRL FIELD indicated enable or disable.
- The service mode switch in RT5202/RT6512 must be set to 1 otherwise its only indication.
- Select the function using the "Exchange" key (G).



**3.3.7.8. Temperature of Heat Sink**

- Use the "VOL knob" (R) to select next menu list step.
- The CTRL FIELD indicated values.
- Two parameters are indicated:
  - Heat sink temperature,
  - Maximum hold temperature of heat sink.

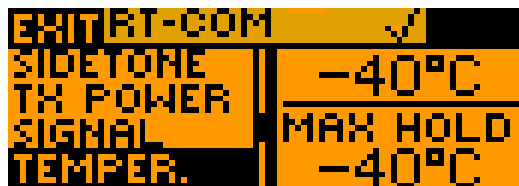

**Note:** Please note that max. hold temperature is reset when you clear eflags.

**3.3.7.9. Self test**

- Use the "VOL knob" (R) to select next menu list step. The text "TEST" is shown.
- The top line from the CTRL FIELD indicated "SELFTEST". Second line indicated "READY" when self test is not running. In the RIGHT KEY window appears "TEST".
- After press the "Exchange" key (G) the test is running and in the second line appears "WAIT".
- When the test result is positiv, than appears in the second line "TEST OK".
- When errors is reported during test the last message is stay on the display for 2 s, then status "READY" appears again.



**3.3.7.10. Errors and Error Flags Indication**

**Note:** There are two indications of errors, when any error is reported an "Err" sign appears in the status field. Detailed information about reported errors is shown in CTRL FIELD of "ERRORS" item. Errors are indicated as "E##" where ## is error unique number.

**Note:** Error flags are reported in similar way. When any error flag is reported an "Err" sign appear in STATUS field. Detailed information about reported error flags are shown in "ERR FLAGS" item. Error flags are indicated as "F##" where ## is error flag unique number.

- Use the "VOL knob" (R) to select next menu list "ERRORS".
- Select in the menu list steps "ERR FLAGS" using the "volume knob" (R).
- Error flags could be cleared to allow this in RIGHT KEY window "CLR" is displayed. The service mode allowed switch must be 1 to clear the flags. Press the "Exchange" key (G) to start the clear sequence. Status of the clear operation is shown in CTRL FIELD. First "WAIT", then " CLEAR..." when operation is in progress and "DONE" for 2 s when finished

Correspondence between error numbers and its meaning:

Error number	Err flag number	Description
E1	F1	Antenna VSWR error (flag)
E2	F2	TX Hot error (flag)
E3	F3	TX Off over temperature error (flag)
E4	F4	Stuck PTT error (flag)
E5	F5	RX Synthesizer error (flag)
E6	F6	RX AGC error (flag)
E7	F7	TX Synthesizer error (flag)
E8	F8	TX Power loop error (flag)
E9	F9	Internal error (flag)
E10	F10	Power supply block error (flag)
E11	F11	Channel error (flag)
-	F12	CU lost connection error flag

Example:

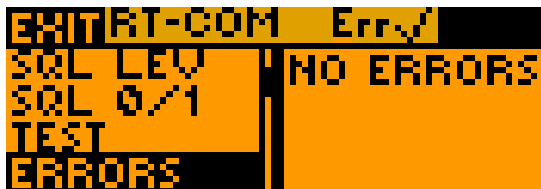

No error is reported



Error flags are reported



No error flag is reported

**3.3.7.11. Last Inspection Date**

- Use the "VOL knob" (R) to select menu list step "INSPEC D".
- Value is editable when service mode allowed switch is 1.
- The "CTRL FIELD" contain on the top "DATE" label current value of inspection date in yy.mm.dd format, below format can be written.
- When value is modifiable then currently selected digit is highlighted.
- Use the "MHz knob" to select the digit.
  - Rotate clockwise to select next digit placed left.
  - Rotate counter clockwise to select previous placed right. Wrap around mechanism is implemented.
- Use the "kHz knob" to selected digits.
  - Rotate clockwise to increase the digit.
  - Rotate counter clockwise to decrease. Only valid dates are selectable.

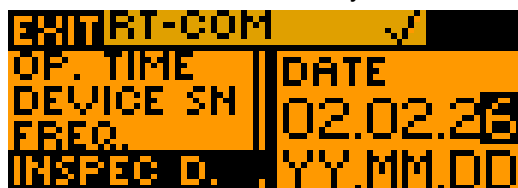

Example: Setting the inspection date:

**3.3.7.12. Operation Time**

- Use the "VOL knob" (R) to select menu list step "OP.TIME".
- Operation time is read only.

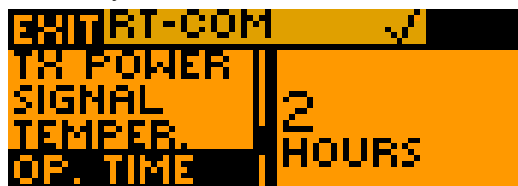

Example: Indication operating time of RT5202/RT6512

**3.3.7.13. Device Change Index**

- Use the "VOL knob" (R) to select menu list step "CHG".
- The device change index is read only.



**3.3.7.14. Device Serial Number**

- Use the "VOL knob" (R) to select menu list step "DEVICE SN".
- Device serial number is read only.



Example: Indication serial number of RT5202/RT6512

**3.3.7.15. Recalling Settings**

- Use the "VOL knob" (R) to select menu list step "RECALL".
- Recalling is possible only when service allowed switch is 1.
  - When recalling is not possible then are the CTRL FIELD and RIGHT KEY field blank.
  - When recalling is possible then appears in the CTRL FIELD "RECALL SETTINGS" and the RIGHT KEY field "REC".
- Press the "Exchange" key (G), in the CTRL FIELD appears "CONFIRM" with two item "NO" and "YES". In the RIGHT KEY window appears "GO".
- Rotate the "kHz knob" clockwise/counter clockwise to select "YES", or "NO".
  - When "NO" is selected press the "Exchange" key (G), to go back to item Recall settings.
  - When "YES" is selected press the "Exchange" key (G), to start the recall procedure.
  - When recall procedure is started in the CTRL FIELD displayed "WAIT..." . After confirmation from RT5202/RT6512 "RECALL...".
  - When recalling is finished then "DONE" is shown for 2 s and RMU goes back to the recall settings.



"REC"

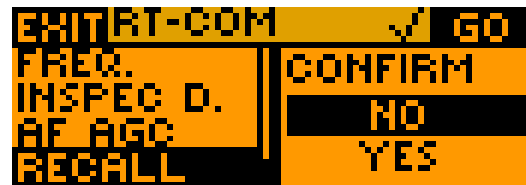

"GO"

**3.3.8. Tandem Operation**

**ADF mode selections**

The possibility that MASTER (RMU5000) and SLAVE (RMU5000) can select different operating modes makes a prioritisation of the ADF operating modes necessary. The work from the left to the right side of mode.

- The BFO has the lowest priority what means that ADF and REC supersede BFO.
- ADF has the highest priority and is superseded by REC.
- The current active mode is always displayed in addition to the left display field of the ADF.

**XPDR mode selections**

The possibility that MASTER (RMU5000) and SLAVE (RMU5000) can select different operating modes makes a prioritisation of the XPDR operating modes necessary. The work from the left to the right side of mode.

- The SBY has the lowest priority what means that ON and ALT will supersede.
- ALT has the highest priority and is superseded by ON also.
- The current active mode is always displayed in addition to the left display field of the XPDR.

**Blank Page**

**Blank Page**

#### 4. Index

Accessories .....	24	Menu for RT3209 .....	60
Additional Conditions of Utilization .....	12	Menu for RT5202/RT6512 .....	63
Additional Required Equipment .....	26	Mounting .....	28
ADF Function .....	55	NAV Function .....	48
CBIT .....	19	Operating .....	45
COM Function .....	45	Operation Instructions .....	41
Connector 1 .....	30, 31	Packaging, Transport, Storage .....	25
Connector Pin Assignments .....	30	Panel and Display Dimming/Illumination .....	20
Continues Built in Test .....	19	PBIT .....	19
Controls and Indications .....	42	Power on Built in Test .....	19
Device Assignment .....	26, 41	Purpose of Equipment .....	15
Dimensions .....	28	Safety Definitions .....	11
Environmental Condition .....	22	Start-Up .....	44
General Description .....	13	Tandem Operation .....	33
IBIT .....	19	Units .....	9
Initiated Built in Test .....	19	User Interface RMU5000-1-XXXX .....	42
Installation .....	25	User Interface RMU5000-2-XXXX .....	43
Installation Setup .....	37	Variants Overview .....	16
List of Abbreviations .....	8	XPDR Function .....	51
Menu for RMU5000 .....	59		

We reserve the right to make technical changes.  
 The data correspond to the current status at the time of printing.  
 © 2016 by Becker Avionics GmbH / all rights reserved

**\*\*\* End of the Document \*\*\***