



## **OPERATING INSTRUCTIONS**

### **Audio Control Unit**

**ACU6101**



Becker Avionics GmbH  
Baden Airpark  
Gebäude B108  
77836 Rheinmünster  
Tel. +49 (0) 7229 / 305-0  
Fax +49 (0) 7229 / 305-217  
E-Mail: [info@becker-avionics.com](mailto:info@becker-avionics.com)  
<http://www.becker-avionics.com>



*Subject to technical changes*

Article No.: 0615.730-071

© Copyright bei / by Becker Avionics GmbH

Table of contents

Blank

	<b>Page</b>
■ Important	3
■ Introduction	3
■ Intercom system	5
1 General	5
2 System Description	5
3 List of Abbreviations	6
4 Operating Controls	7
5 Description and Function of the Operating Controls and Indicators	8
6 Operating Instructions	11
6.1 Preparations (power-up test)	11
7 Transceiver operation	13
7.1 Transceiver monitoring	13
7.2 Individual Transceiver Channel Volume Adjustment	13
7.3 Monitored TX-Channel Visualization	14
7.4 Main Volume Adjustment	14
8 Selection of Transmission Mode	14
8.1 Selecting a radio for transmission	15
8.2 Selection of Intercom PTT	15
8.3 Forced monitoring	15
8.4 Transmission Mode	16
9 Receiver Operation	18
9.1 Receiver Monitoring	18
9.2 Individual Receiver Channel Volume Adjustment	19
9.3 Monitored RX-Channel Visualization	19
9.4 Main Volume Adjustment	20
9.5 Voice Filter Activation	20

	<b>Page</b>	
9.6	Loudspeaker Operation	21
10	Intercommunication	23
10.1	Virtual Intercom Circuits	23
10.2	Cockpit "ISOL/CALL" Functionality	26
10.3	Cabin "ISOL/CALL" Functionality	26
11	Intercom Activation	28
11.1	Voice Controlled Intercom	28
11.2	VOX Level Adjustment	29
11.3	PTT Controlled Intercom	29
11.4	External Switch Controlled Intercom	30
11.5	IC Volume Adjustment	30
11.6	Winchmann Intercom	31
11.6.1	Winchmann VOX Level Functionality	31
11.6.2	Winchmann Volume Level Functionality	31
11.7	Emergency CALL Function	32
11.8	Selective CALL Function	32
11.9	Allocation of Selective CALL	32
11.10	Selective CALL Indication	33
11.11	Selective CALL Forced Monitoring	33
12	Built In Test (BITE)	33
12.1	Power-Up Built In Test (P-BIT)	33
12.2	Continuous Built In Test (C-BIT)	34
13	Emergency Operation	34
13.1	Slaved Operation	34
13.2	Back-Up Operation Switch Activated	35
13.3	Back-Up automatic activation	36
14	Special Version ACU6101-X-(YXXXX)	36
14.1	Dual, Multi Transmission mode	37

Blank

By pressing a PTT switch (on panel or external), the transmission is indicated by the corresponding green LED's flashing as long as the PTT switch is held.

By configuration the system is able to be configured for Dual TX or Multi TX operation. The simulcast transmission mode can be blocked by system configuration.

### **Important**

Carefully read these operating instructions before attempting to operate the Audio Control Unit.

Keep these operating instructions for future reference. They contain important safety and operating instructions for the Audio Control Unit.

### **Introduction**

Thank you for purchasing the BECKER Audio Control Unit.

If you have any questions regarding the operation of the Audio Control Unit, please get in touch with your nearest Becker Dealer or with Becker Customer Service.

The CAUTION, WARNING and NOTE highlights have the following meanings:

<b>WARNING</b>	Failure to comply or incorrect compliance with these instructions or procedures can lead to injuries or fatal accidents.
<b>CAUTION</b>	Failure to comply, or incorrect compliance, with these instructions or procedures can lead to damage to equipment.
<b>NOTE</b>	Feature to which attention should be drawn.

The selection of the two transceiver for dual transmission is configured during installation setup of the control unit.

By pressing a PTT switch (on panel or external), the transmission is indicated by the corresponding green LED's flashing as long as the PTT switch is held.

By configuration the system is able to be configured for Dual TX or Multi TX operation. The dual transmission mode can be blocked by system configuration.



### Multi Transmission

If the TX-selector rotary switch is turned to position "D/S", the operator activates (TX-knob released) several transceivers simultaneously for transmission. The green LED's (transceiver monitoring) from the selected transceivers illuminate. The selection of the function for simulcast is configured during installation setup of the control unit.

### 13.3 Back-Up automatic activation

When the two main power supply busses fail or if a fatal defect occurs within the unit's internal supply, the security logic falls back to Back-Up operation even if the "BACK-UP" switch had not been activated.

## 14 Special Version ACU6101-X-(YXXXX)



This ACU6101-X-(XXXX) supports control of 8 TX-CHANNEL. Two remaining RX-CHANNEL can be still used. In addition Double Transmit or Simulcast can be configured during configuration setup.

### 14.1 Dual, Multi Transmission mode

#### Dual Transmission

If the TX-selector rotary switch is turned to position "D/S", the operator activates 2 transceiver simultaneously for dual transmission. The green LED's (transceiver monitoring) from the selected transceivers illuminate.

## Intercom System

### 1 General

The intercom system is part of the aircraft's radio and audio system. It enables the crew to communicate with each other and to monitor the radio, identification and warning signals.

### 2 System Description

The Intercom System provides the following modes of operation:

- Hot mike operation for all crew members.
- Intercommunication between pilot and copilot.
- Intercommunication among the passengers.
- Connected or separated intercommunication for cockpit and cabin crews.
- Intercommunication between cabin crew and pilots. If a cabin crew member pushes a "CALL" button, a call signal is generated (configurable) and is audible in the headsets cockpits. Simultaneously a call annunciator will illuminate. The pilots then may communicate individually.
- Individual transmitter operation for both, pilot and copilot, with either one of the radios available or two of it for dual transmission (configurable), including sidetone monitoring.
- Individual transmitter operation for the cabin crew, including sidetone monitoring.
- Discrete or collective radio reception of audio signals for the pilots and crew.

**3 List of Abbreviations**

ACU	Audio Control Unit
dB	Decibel
FIX	Fixed Input
IC	Intercommunication
ISOL/CALL	Isolate / Request Call
LRU	Line replaceable unit
LED	Light Emitting Diode
PA	Public Address
PTT	Push-to-Talk-key
REU	Remote Electronic Unit
RX	Receiver
SPKR	Speaker
TX	Transceiver
VOL	Volume
VOX	Voice Operated Switch

When switching the rotary switch to position "SLAVED" on ACU 1 or ACU 2, the matching headset is disconnected from its audio processing circuits in the Remote Electronic Unit and its mike and phone capsules are directly paralleled to the headset of the remaining ACU.

No further action is possible on the slaved Audio Control Unit. "SLAVED" mode is a first step of security in case where one of the control panels appears to be defective or not working.

**13.2 Back-Up switch activated**

The pilot or copilot have the possibility to activate the back-up mode by switching the rotary switch to position BCK (after unlocking by pulling its lever) in position "BCK".

In this mode, the microphone and headphone amplifier is powered via an external emergency supply provided by the aircraft.

The following signal routings and functionalities are active in back-up mode:

- Headphone 1 - TX 1 & FIX 1
- Headphone 2 - TX 2 & FIX 2
- Intercom volume level is fixed to 50%  
CVR ½ level is fixed to 50%
- No actions on the ACUs are supported



- By pressing any button on panel, the failure can be acknowledged. In case of a permanent problem inside the system, it will be detected by the continuous self test routine and indicated again.
- Switching into the slaved or emergency mode by using the rotary switch.

## 12.2 Continuous built in test (C-BIT)

During normal operation of the system, a permanent background test routine is continuously running. If an error is detected, the "TEST" LED starts to flash. If it is not a fatal error, the operator can acknowledge the failure by pressing the any button.

In case of notable degradation in unit or system performance, the operator can turn to emergency operation, either in "SLAVED" or "BACK-UP" mode.

## 13 Emergency operation

### 13.1 Slave operation

Copilot ACU

Pilot ACU



## 4 Operating Controls

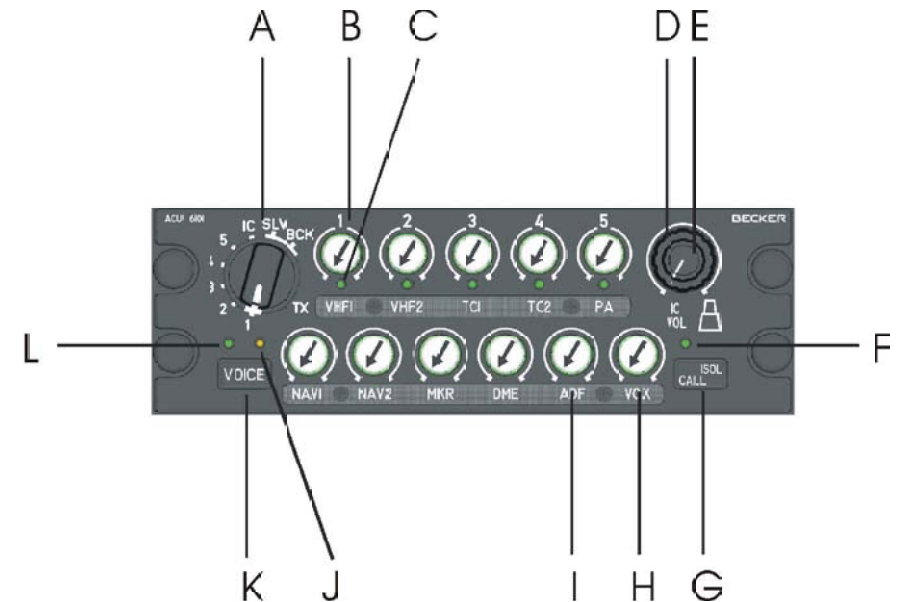

Fig. 3-1 Front Panel of the Audio Control Unit

**5 Description and Function of the Operating Controls and Indications**

Item	Control / Indicator	Description	Function
A	Transmitter selector switch	Rotary switch with 8 lock positions	Position 1 to 5 Preselection of TX channel for transmission  Position IC Intercom PTT mode  Position SLV Selection of Slave mode  Position BCK Backup mode
B	TX1 to TX5 controls	5 potentiometer with push-push switches	On/Off switch for each TX channel and individual volume adjust for audio monitoring

**11.10 Selective CALL indication**

As long as the “Selective CALL” discrete input is activated, the LED below the associated TX-channel will blink with double frequency. The operator can react to this indication by activating the corresponding channel for monitoring (if not yet done) or starting communication.

**11.11 Selective CALL forced monitoring**

If forced monitoring for “Selective CALL” is activated in the configuration of the system, the associated TX-channel is automatically monitored as long as the selective CALL is active.

If this channel is being already monitored, there is no additional action.

**12 Built in test**

**12.1 Power-up built in test (P-BIT)**

Every time the system is powered, an internal self test procedure is started.

While the test is running, the Test LED illuminates. The test lasts up to 4 seconds. After the test, the following results are shown:

- No failure detected yellow LED is off; the system is in normal mode
- Failure detected yellow LED is blinking

If the internal test routine detected an failure (yellow LED is blinking), the operator has 2 possibilities:

panel. The VOX level can be reset also, when the main volume control on the related ACU is changed.

**11.7 Emergency CALL function**

The System provides an “Emergency CALL” (E-CALL) via a dedicated discrete input. If this discrete input is activated, the “E-CALL” tone is audible for cockpit ACU operators. The “E-CALL” tone is different from the intercom request CALL- tone.

The “E-CALL” functionality can be deactivated via system configuration.

**11.8 Selective CALL function**

A “Selective CALL” functionality is provided by the System in a configurable way.

The system detects selective call status via a discrete input line.

The behaviour of the Audio Control Unit selective CALL functionality can be selected by configuration of the system.

**11.9 Allocation of “Selective CALL”**

The “Selective CALL” function can be allocated to one of the 8 TX-channels white system integration setup.

Item	Control / Indicator	Description	Function
C	TX indicators 1 to 5	5 LED (green)	<p>Indication of individual TX channel status</p> <p>LED on Channel is preselected for transmission</p> <p>LED blinking Transmission is active</p> <p>LED blinking Selective “CALL” is active fast</p>
D	Volume control	Potentiometer	Main volume control
E	IC volume control	Potentiometer	Volume adjustment for intercom
F/L	“ISOL/ CALL” indicator	LED (green)	<p>LED on Cockpit and cabin intercom circuits are isolated</p> <p>LED off Cockpit and cabin intercom circuits are connected</p> <p>LED blinking Intercom request “CALL” is active</p>

Item	Control / Indicator	Description	Function
G/K	“ISOL/ CALL” button	Push-button	<p><b>Cockpit:</b> Connect or truncate the cockpit and cabin intercom circuits</p> <p><b>Cabin:</b> Initiates an intercom request “CALL” if the intercom circuits are isolated</p>
F/L	“VOICE” indicator	LED (green)	<p>LED on = voice filter is active</p> <p>LED off = voice filter is not active</p>
G/K	“VOICE” button	Push-button	On/Off switch for VOICE filter (for configured RX channels)
G	PTT button	Push-button	<p>Button pressed</p> <p>Selected transmitter is keyed</p>
F/L	Speaker indicator	LED (green)	<p>LED on = Speaker is on</p> <p>LED off = Speaker is off</p>
G/K	“Speaker” button	Push-button	ON/OFF switch for audio monitoring via the speaker

## 11.6 Winchman intercom

By pressing the special external push button the winchman function is activated.

With this, the winchman is able to increase the VOX level and the main volume for his headset. The external push buttons (connected via discrete input lines`at REU6100) are mounted separately from the corresponding ACU in the winchman working area (near the cabin door).

By configuration, it is possible to assign the winchman functionality to any ACU.

The following sub paragraphs describe the winchman external buttons functionality in detail.

### 11.6.1 Winchman VOX level functionality

If the VOX level push button is pressed for a short time (0.3s to ≤ 3s), the VOX level is increased by one step, until the maximum value is reached. If the VOX level push-button is pressed for a time ≥ 3s, the VOX level will be reset to the value selected on the corresponding ACU panel. The VOX level can be reset too, when the volume control or VOX control on the ACU is changed.

### 11.6.2 Winchman volume level functionality

If the winchman volume push button is pressed a short time (0.3s to ≤ 2s), the volume level is increased by one step, until the maximum value is reached. If the winchman volume push button is pressed for a time ≥ 3s, the volume level will be reset to the value selected on the corresponding ACU

**11.4 External switch controlled intercom**

Each ACU supports an external momentary or 2-state switch for activation of a "Hot Mike Mode". If this switch is activated, the mike line is "open" and the signal is forwarded directly to the intercom amplifier.

**11.5 IC volume adjustment**



For individual intercom volume adjustment, the ACU provides a dedicated potentiometer on the front panel. The intercom volume is independent from the main volume.

The transmission mode always has a higher priority than the intercommunication mode. If an operator activates the transmission mode for any transceiver, the ACU stops its "VOX" or "HOT MIKE" mode and carries out transmission mode. Other ACUs are not affected and their operators may continue intercommunication.

Item	Control / Indicator	Description	Function
H	VOX level adjustment VOX ON/OFF switch	Potentiometer with push-push switch	VOX sensitivity selection  ON/OFF switch for VOX activation
I	RX1 to RX5 controls	5 potentiometer with push-push switches	On/Off switch for each RX channel and individual volume adjust for audio monitoring
J	"TEST" indicator	LED (yellow)	LED on Internal self test is running  LED blinking The internal selftest detected an failure

**6 Operating instructions**

**6.1 Preparations (power-up test)**

1. Switch on the unit by using the audio selector master switch (circuit breaker).
2. When the Audio Control Unit is powered, the device starts an internal self test procedure. All the microprocessors and memories are tested as well as data transfer between Audio Control Units and Remote Electronic Unit.

While test is running, the yellow TEST LED illuminates. The test needs about 4 seconds.

After the test the following results are shown:

- No failure detected yellow LED is off; the system is in normal mode
- Failure detected yellow LED is blinking

If internal test routine detected an failure (yellow LED is blinking), the operator has 2 possibilities:

- By pressing of any button on the panel the failure can be acknowledged. In case of a permanent problem inside the system, it will be detected by continuous self test routine and indicated again.
- Switching into slaved or emergency mode by using the rotary switch.



### 11.2 VOX level adjustment

The VOX level of the microphones associated with each ACU can be adjusted independently for each ACU by turning the VOX potentiometer knob.



### 11.3 PTT controlled intercom

Setting the TX selector to position IC, enables intercom by using the PTT button. In this case, the mike signal is forwarded to the intercom amplifier when the PTT switch is pressed only.

### 11 Intercom activation

Intercommunication between the different users can be activated in three ways:

- Voice controlled
- PTT controlled
- External Switch controlled

#### 11.1 Voice Controlled Intercom

In positions "1" to "5" of the TX selector rotary switch, Voice Controlled Intercom (VOX) is established without the need for any further action (assuming no transmitter is keyed).

Voice Controlled Intercom can be activated or deactivated by switching functionality of the VOX knob.

- VOX knob released      Voice Controlled Intercom ON
- VOX knob impressed      Voice Controlled Intercom OFF

The switch function of the VOX knob can be activated or deactivated by the Configuration Software.

### 7 Transceiver operation

#### 7.1 Transceiver monitoring



For transceiver monitoring, a TX-channel is activated by push release of the respective knob.

- Knob released      monitoring ON
- Knob impressed      monitoring OFF

Several transceivers may be selected for monitoring at the same time.

#### 7.2 Individual transceiver channel volume adjustment

The individual volume for the monitored channels can be selected by turning the respective knob.

### 7.3 Monitored TX-channel visualization

The activated TX-channel (released) knobs are illuminated.

By looking at the panel from an angle that's unequal to the rectangular top view, it's easy to detect the activated and deactivated channels.

An arrow on top of each knob helps the user to pick the selected volume of the several channels quickly.

### 7.4 Main volume adjustment

Main volume can be adjusted at any time by turning just the VOL control. This action adjusts the sum volume of all activated TX- and RX-channels and the fixed inputs 4 to 6.

## 8 Selection of transmission mode



- LED off      Cockpit and cabin intercom circuits are connected
- LED blinking      The "CALL" button was pressed and the system is in call mode. By pressing the "ISOL/CALL" key at his Audio Control Unit the pilot or copilot can reestablish the connection between the passengers. While the LED indications are blinking, a CALL tone is audible in the cockpit. The "CALL" tone can be enabled/disabled by configuration.
- LED on      The intercom system is in isolation mode

If the system is in call mode (blinking LED), there are two possibilities:

- the cockpit crew leave the isolation mode and connect the intercom circuits (LED off).
- the cabin crew presses the "CALL" button once again and the system stays in isolation mode (LED on).

If the intercom circuits are connected (no isolation mode), the "ISOL/CALL" button on the cabin ACUs have no function.



By using an additional ground crew box (e.g. Becker EB3100) ground crew can be connected with the intercom system. That ground crew is representing a fourth intercom circuit which is connected with the cockpit intercom circuit of the DVCS6100 system.

### 10.2 Cockpit "ISOL/CALL" Functionality

In the cockpit, the "ISOL/CALL" button is used to toggle the connection/disconnection between the cockpit and the cabin intercom circuits.

A LED above this button indicates the actual status of the connection:

- LED on → cockpit and cabin intercom circuits are isolated
- LED off → cockpit and cabin intercom circuits are connected

### 10.3 Cabin "ISOL/CALL" Functionality

The "ISOL/CALL" button on the cabin ACUs gives the cabin passengers the possibility to call for a connection. The cockpit crew can react to this call by ending the isolation mode.

The LED above the "ISOL/CALL" button shows the call status in the following way:

### 8.1 Selecting a radio for transmission

For transmission with an individual radio, the transceiver is pre-selected by means of the TX-selector rotary switch of the Audio Control Unit. In the given example TX-channel 1 is pre-selected for transmission. The green LED illuminates (TX channel 1).

### 8.2 Selection of intercom PTT

The last unlocked position (by turning clock wise) "IC" of the TX-selector rotary switch selects the "intercom by PTT" mode.

### 8.3 Forced monitoring

The reception signal of the radio which is pre-selected for transmission is monitored, even if it was not active for monitoring before (forced monitoring).

Using the respective knob, the monitoring volume can be adjusted.

Forced monitoring can be deactivated during installation setup by configuration.

With activated "Forced Monitoring", in the following example, TX-channel 1 would be audible thus it is not manually activated (knob not released).



### 8.4 Transmission mode

If transmission mode is activated by pressing a PTT button (on panel or external) the selected transmitter will be keyed and the corresponding status green LED is blinking.



### Intercom extension for Ground Crew:

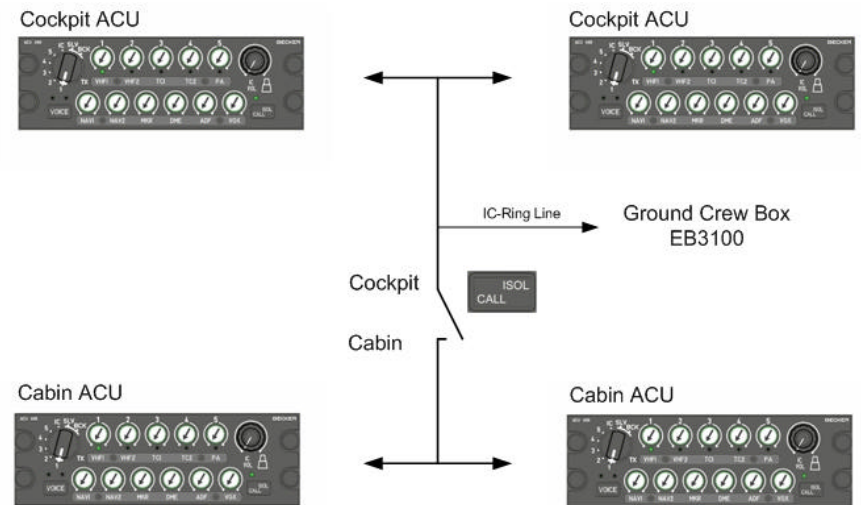

**Intercom extension for passengers:**

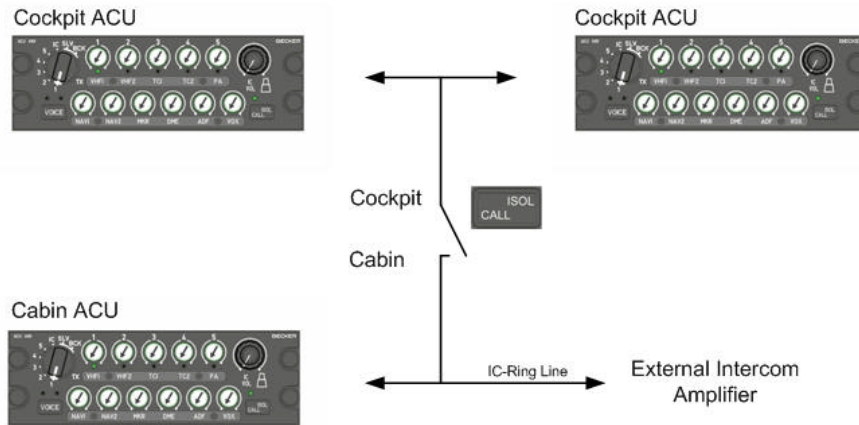

By using an additional intercom amplifier (e.g. Becker IC3100) passengers can be connected with the intercom system. These passengers are representing a fourth intercom circuit which is connected with the cabin intercom circuit of the DVCS6100 system. It can be truncated by an external switch which is not shown in the above diagram.

- The green LED below the associated channel volume knob is flashing.

**Note:**

Only those warning tones which have been programmed as essential during installation setup, are still audible when transmitting.

If loudspeakers are provided and if the one related to the individual control unit had been switched on prior to transmitting, it will be muted to avoid acoustic feedback to the microphone.

By speaking into the microphone while in transmission mode, the following actions will result:

- The activated transmitter is modulated
- A sidetone is audible with a volume that is in accordance with the preselection in the installation setup. The individual volume for the monitored channels can be selected by turning the respective knob.
- The TX indications (blinking LED) assigned to an individual transmitter is active on all ACUs when keyed by any operator.
- Any transmitter could be modulated by different operators simultaneously.

By releasing the PTT switch (on panel or external), the following actions will result:

- The transceiver turns back to receive mode
- The green LED lights up (stops flashing)
- All previously selected signals, intercom, and warning tones are resumed.

- If the loudspeaker was activated before pressing PTT, it is switched on again.



## 9 Receiver operation

### 9.1 Receiver monitoring

For receiver monitoring, a RX-channel is activated by push release of the respective knob:

- Knob released → monitoring ON  
 Knob impressed → monitoring OFF

## 10 Intercommunication

### 10.1 Virtual Intercom Circuits

There are four Intercom Circuits provided by the DVCS6100 System.

1. Cockpit Crew
2. Cabin Crew
3. Third Circuit (controlled by an external switch, refer to the REU6100 manual)
4. IC-Ring Line (connected to the cabin, Cockpit or 3rd intercom circuit; configurable by the CSW - Software).

Two of the intercom circuits (Cockpit and Cabin) can be directly controlled by the Control Unit.

The Intercom between cockpit and cabin can be truncated by pressing the "ISOL/CALL" push button. When the intercom mode between cockpit and cabin is interrupted, the green LED above the "ISOL/CALL" button is illuminated.



When speaker mode is active with an individual Audio Control Unit, voice controlled intercommunication (VOX) is disabled.

Intercom is still possible by activating the external IC button or by pressing the PTT button while the TX-selector rotary switch is in position "IC". In both cases, the loudspeaker is muted to avoid acoustic feedback.



Several receivers may be selected for monitoring at the same time.

In the given example, RX-channel 1, 2 and 4 are selected for monitoring.

### 9.2 Individual receiver channel volume adjustment

The individual volume for the monitored channels can be selected by turning the respective knobs.

### 9.3 Monitored RX-channel visualization

The activated RX-channel (released) knobs are illuminated.

By looking at the panel from an angle that's unequal to the rectangular top view, it's easy to detect the activated and deactivated channels.

An arrow on top of each knob helps the user to pick the selected volume of the several channels quickly.

### 9.4 Main volume adjustment

Main volume can be adjusted at any time by turning the VOL control. This action adjusts the sum volume of all activated TX- and RX-channels.

### 9.5 Voice filter activation

**Note:**

This function is not available for all variants of ACU6101.

The system has the possibility to activate a 1020Hz notch filter for all the RX-channels. This is to suppress identification codes in the incoming audio signals from navigation receivers (e.g. for listening to weather information).

In the configuration of the system, the system integrator can define the RX-channels that will have this filter.

Whilst operating, the filter can be activated and deactivated by pressing the "VOICE" push button. The status of voice filter activation is visible by a green LED in top of that push button:

- "VOICE" LED on voice filter is active
- "VOICE" LED off voice filter is not active

### 9.6 Loudspeaker operation

**Note:**

The system provides two speaker channels which are assigned in the standard version to ACU1 and ACU2. This function is not available for all variants of ACU6101.

Pressing the "SPKR" button briefly, switches on the loudspeaker that is related to this control unit. All selected TX/RX channel signals and warnings are reproduced through the loudspeaker. The green LED above the button indicates the speaker mode.

Pressing the key once again, the speaker is switched off and the LED goes off.

